

# TANCO AUTOWRAP 580 A MODEL HYDRAULIC CIRCUIT DIAGRAM

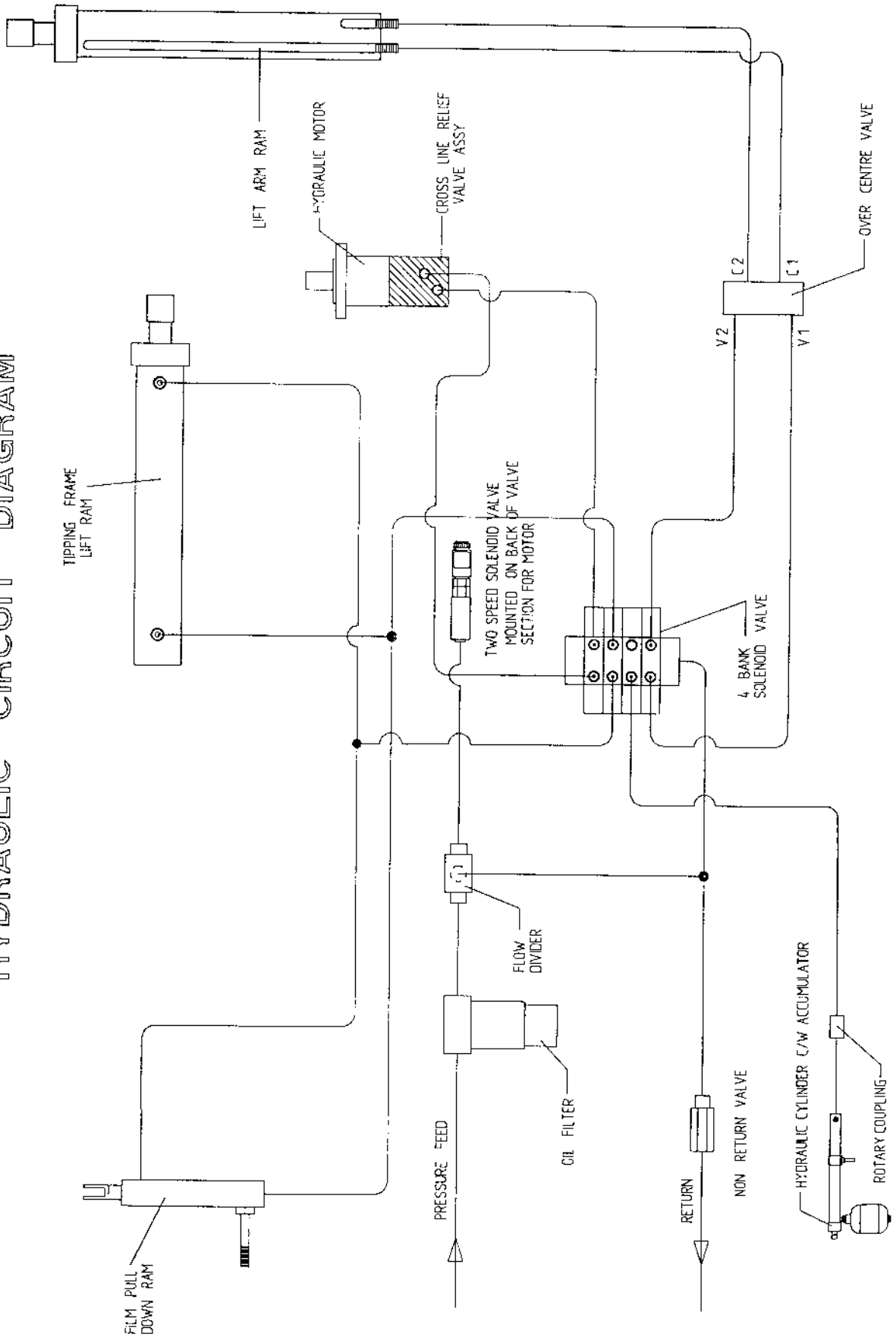

# TANCO AUTOWRAP 580 S MODEL HYDRAULIC CIRCUIT DIAGRAM

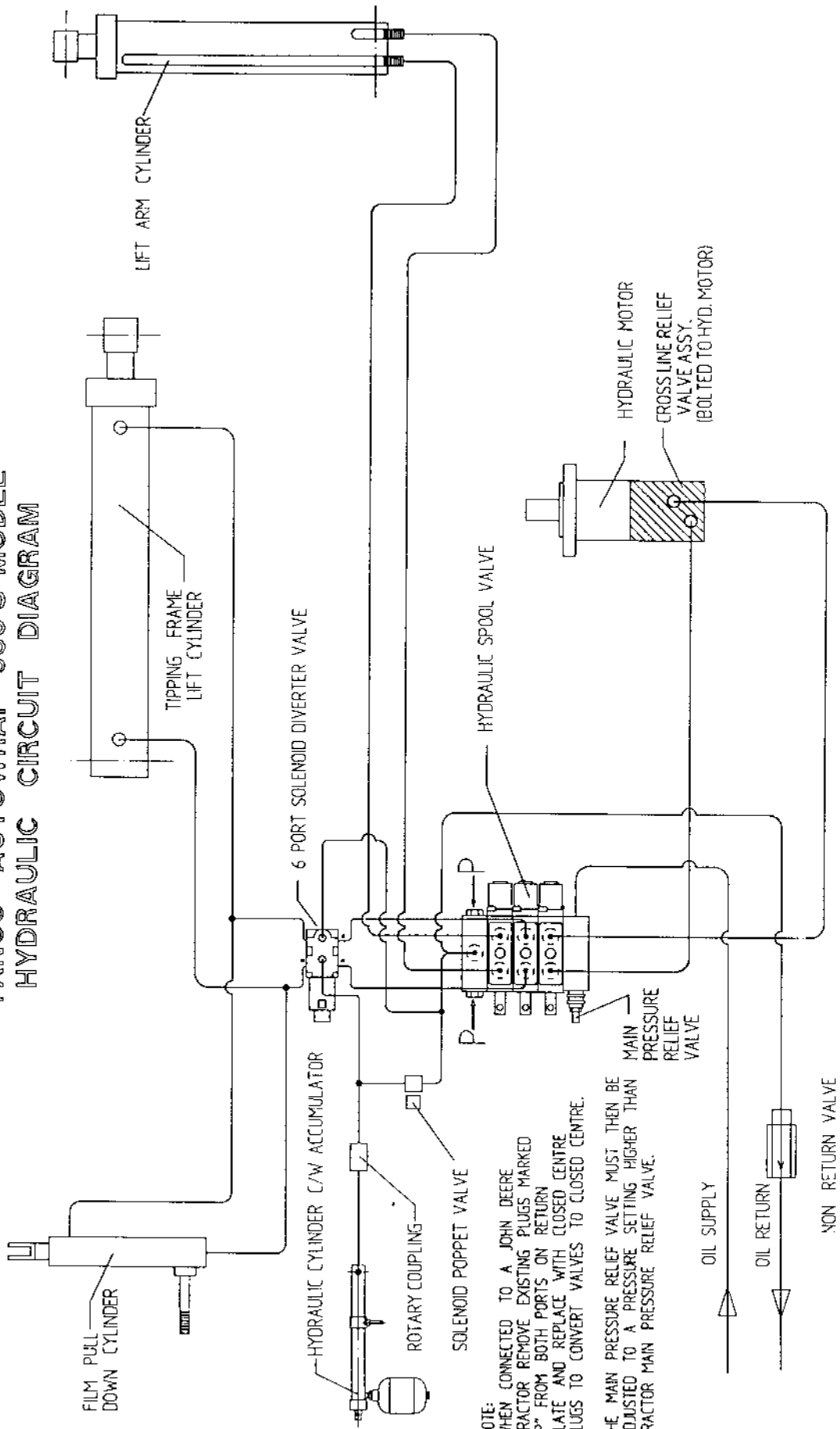

NOTE:  
 WHEN CONNECTED TO A JOHN DEERE TRACTOR REMOVE EXISTING PLUGS MARKED "P" FROM BOTH PORTS ON RETURN PLATE AND REPLACE WITH CLOSED CENTRE PLUGS TO CONVERT VALVES TO CLOSED CENTRE.

THE MAIN PRESSURE RELIEF VALVE MUST THEN BE ADJUSTED TO A PRESSURE SETTING HIGHER THAN TRACTOR MAIN PRESSURE RELIEF VALVE.

**INSTRUCTION FOR FITTING TWO WAY SOLENOID VALVE CLOSED CENTRE  
CONVERSION KIT TO TANCO AUTOWRAP 580A MODEL.**

**REQUIRED WHEN OPERATING MACHINES ON TRACTORS WITH CLOSED CENTRE  
HYDRAULIC SYSTEMS.**

1. Disconnect St/19'm hose from inlet port on oil filter.
2. Connect port "T" on solenoid valve assembly to inlet port on oil filter.
3. Reconnect St/90 hose to port "P" on solenoid valve.
4. Connect 2 pin female connector to existing 2 pin connector at junction box.
5. Change the seventh controller function setting from n to J. See instruction manual for further information.

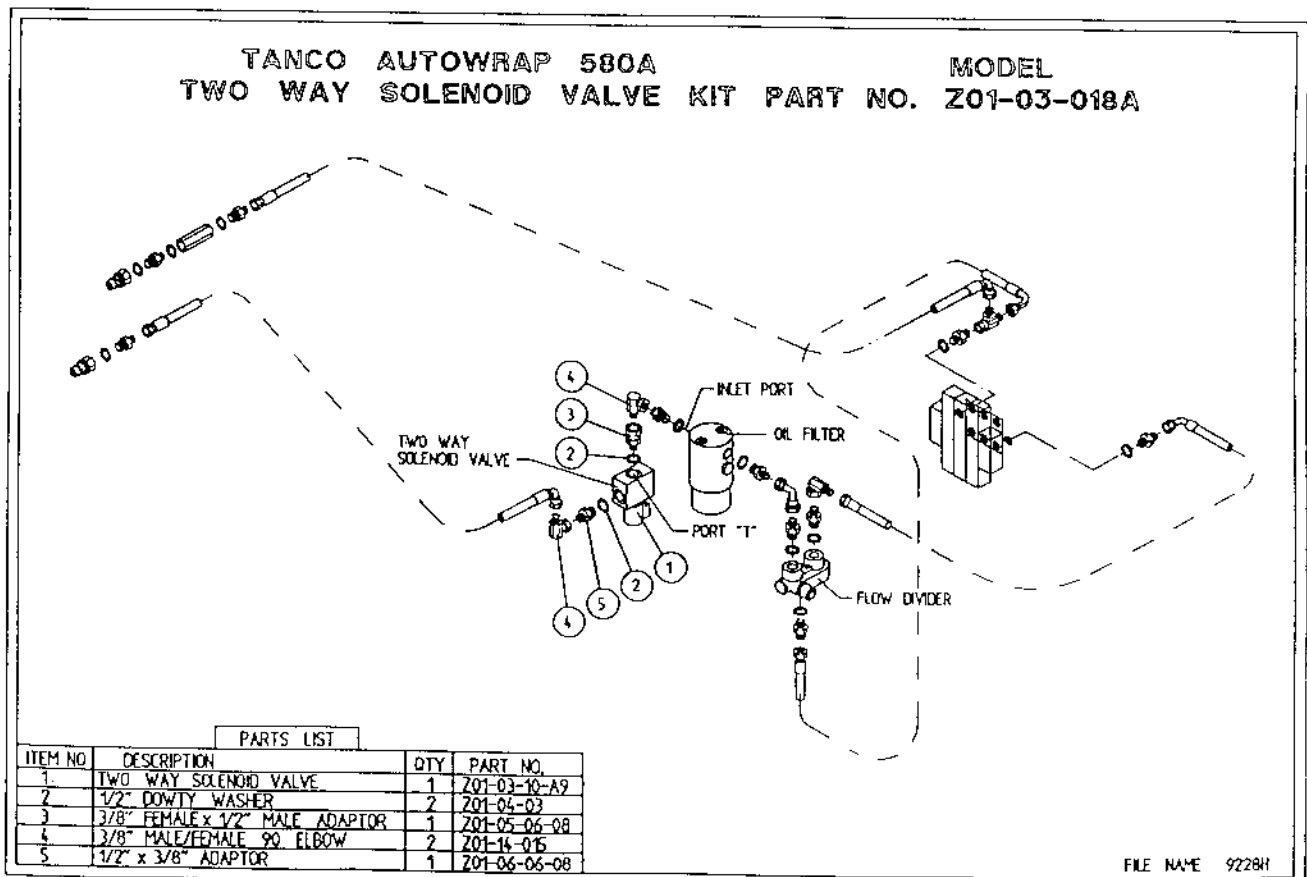

# TANCO AUTOWRAP 580 S MODEL HYDRAULIC COMPONENTS

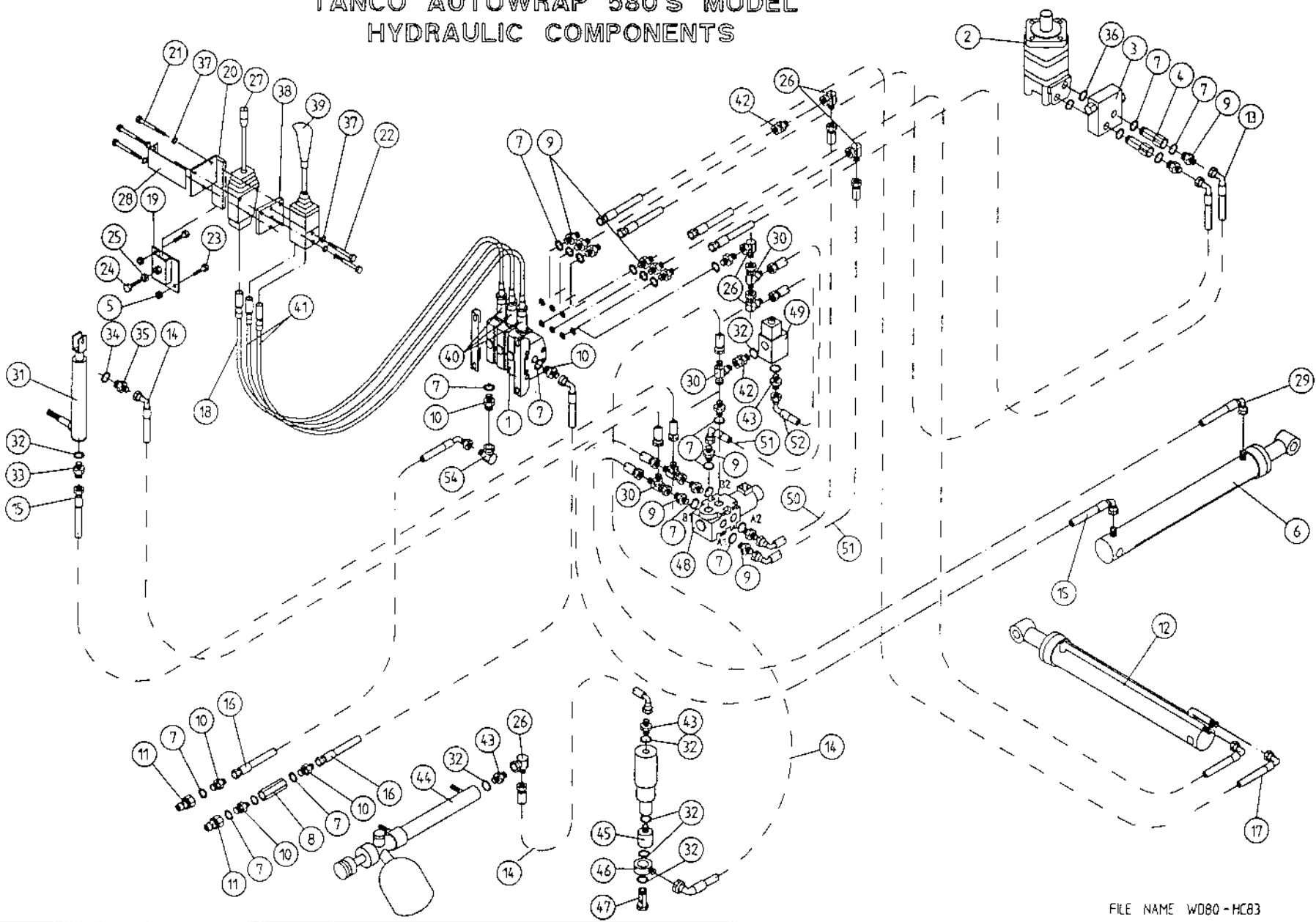

FILE NAME WD80-HC83

**TANCO AUTOWRAP 580S MODEL  
HYDRAULIC COMPONENTS  
PARTS LIST**

ITEM NO	DESCRIPTION	QTY.	PART-NO
1	3 BANK SPOOL VALVE (DIN)	1	Z01-03-018D
2	HYDRAULIC MOTOR	1	Z01-02-RF200
2A	SEAL KIT FOR ABOVE	1	Z01-RF-200
3	CROSS LINE RELIEF VALVE	1	Z01-03-004
4	1/2" BSP BOTTOM BANJO BOLT (SPECIAL)	2	Z01-03-002B
5	M10 LOCKNUT	3	Z23-10
6	HYD. RAM ( FOR TIPPING FRAME)	1	Z01-01AR687
6A	SEAL KIT FOR ABOVE HYD. RAM	1	Z01-Z01
7	1/2" DOWTY WASHERS	18	Z01-04-03
8	1/2" NON RETURN VALVE	1	Z01-03-017
9	1/2" x 3/8" ADAPTOR	10	Z01-06-06-08
10	1/2" x 1/2" ADAPTOR	3	Z01-06-08-08
11	1/2" MALE END Q/R COUPLING	2	Z01-15-081
12	HYD RAM (FOR LIFT ARM)	1	Z01-01-AW
12A	SEAL KIT FOR ABOVE HYD. RAM	1	Z01-Y01
13	108" ST/90 3/8" D/W HOSE	3	Z38-R2-108-S9
14	72" ST/90 3/8" D/W HOSE	1	Z38-R2-72-S9
15	48" ST/90 3/8" D/W HOSE	1	Z38-R2-48-S9
16	108" ST/90 1/2" D/W HOSE	1	Z12-R1-108-S9
17	84" ST/90 3/8" D/W HOSE	3	Z38-R2-84-S9
18	3.5M ACTUATOR CABLES	1	Z004-03-0075
19	ACTUATOR MTG BRACKET (LOWER)	1	WD65-AML
20	ACTUATOR MTG BRACKET (UPPER)	1	WD65-AMU
21	M8 x 60 HEX BOLT	3	Z26-047B
22	M8 x 70 HEX BOLT	2	Z26-049B
23	M10 HEX HD SETS x 40mm LONG	3	Z26-064S
24	M12 HEX HD SET x 40mm LONG	1	Z26-084S
25	M12 HEX NUT	1	Z18-12
26	3/8" MALE x 3/8" FEMALE 90 ELBOW	1	Z01-14-015
27	ACTUATOR LEVERS	1	Z004-03-009
28	STICKER MOUNTING PLATE	1	WD60-794
29	30" ST/90 3/8" D/W HOSE	1	Z38-R2-30-S9
30	3/8" FEMALE x 3/8" MALE/MALE "T" PIECE	2	Z01-12-002
31	PULL DOWN RAM	1	Z01-01-AW25
31A	SEAL KIT FOR ABOVE HYD. RAM	1	Z01-AW25
32	3/8" DOWTY WASHER	1	Z01-04-02
33	3/8" x 3/8" ADAPTOR FITTED WITH 0.06" RESTRICTOR	1	Z01-03-40
34	1/4" DOWTY WASHER	1	Z01-04-01
35	1/4" x 3/8" ADAPTOR	1	Z01-06-04-06
36	COPPER WASHER	1	Z01-04-15
37	8mm SPRING WASHER	1	Z12-02-08
38	ACTUATOR/JOYSTICK ADAPTOR PLATE	1	AY15-072
39	JOYSTICK ACTUATOR	1	Z004-03-013
40	CABLE FITTING KIT DIN OIL.	3	Z004-03-014
41	3.5M JOYSTICK CABLE	1	Z004-03-00753
42	3/8" MALE/FEMALE ADAPTOR	1	Z01-05-06-06
43	3/8" MALE/MALE ADAPTOR	1	Z01-06-06-06
44	CUT AND START RAM	1	Z01-01-AWH9
44A	SEAL KIT FOR ABOVE HYD. RAM	1	Z01-AWH
45	ROTARY COUPLING	1	Z01-01-AWR
46	3/8" BANJO COUPLING	1	Z01-19-062
47	3/8" SINGLE TOP BANJO BOLT	1	Z01-20-062
48	6 PORT SOLENOID VALVE	1	Z01-03-105-06
49	2 PORT SOLENOID POPPET VALVE	1	Z01-03-103
50	30" ST/90 3/8" D/W HOSE	2	Z38-R2-30-S9
51	18" ST/90 3/8" D/W HOSE	1	Z38-R2-18-S9
52	14" ST/90 3/8" D/W HOSE	1	Z38-R2-14-S9
53	96" ST/90 3/8" D/W HOSE	1	Z38-R2-96-S9
54	1/2" MALE x 1/2" FEMALE ELBOW	1	Z01-14-016

# TANCO AUTOWRAP 580 A MODEL HYDRAULIC COMPONENTS

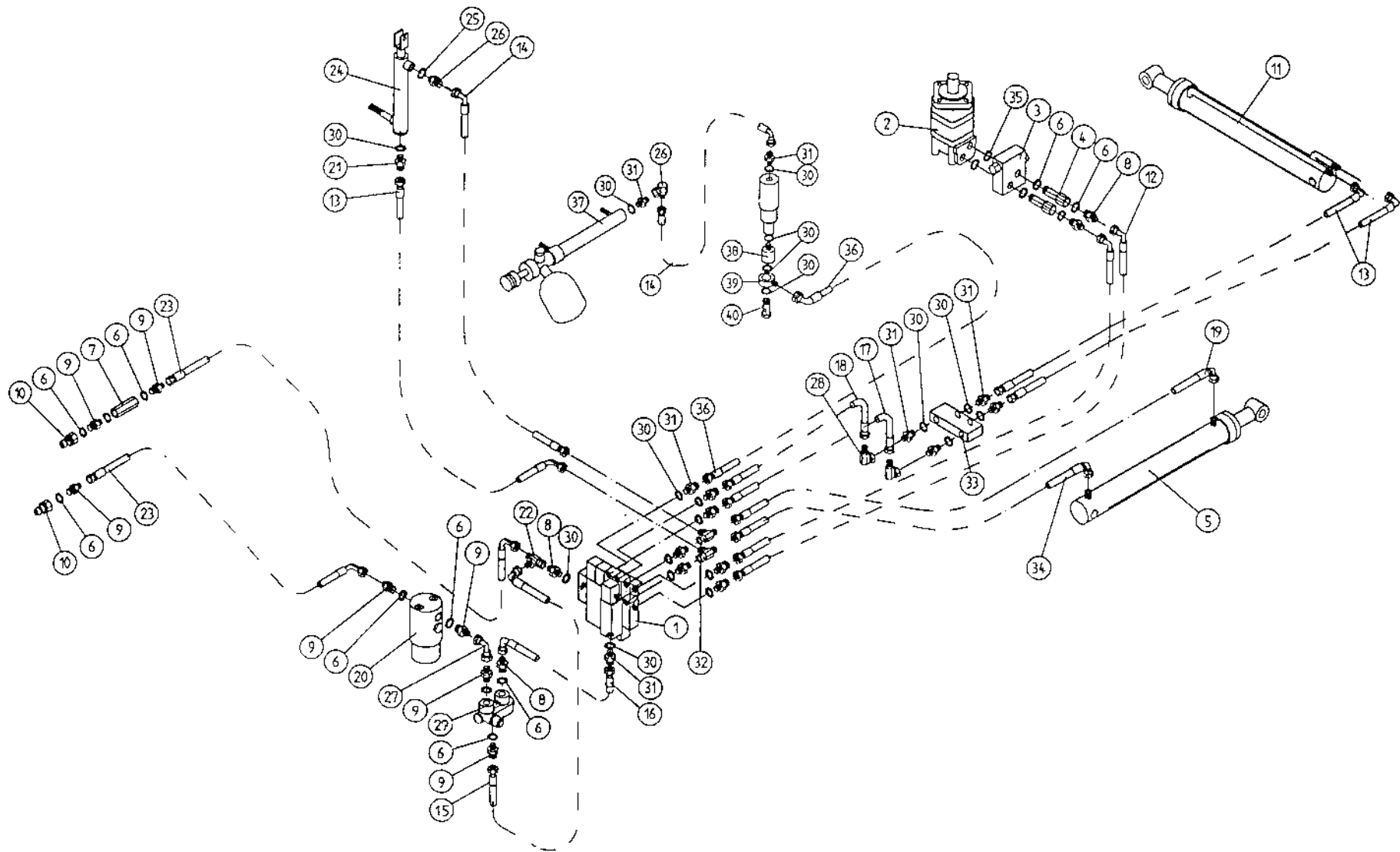

TANCO AUTOWRAP 580A MODEL  
HYDRAULIC COMPONENTS

PARTS LIST

ITEM NO.	DESCRIPTION	QTY	PART-NO
1	4 BANK SOLENOID VALVE	1	Z01-03-A550
2	HYDRAULIC MOTOR C.L.	1	Z01-02-RF200
2A	SEAL KIT FOR ABOVE RAM	1	Z01-RF-200
3	CROSS LINE RELIEF VALVE	1	Z01-03-004
4	1/2" B.S.P. BOTTOM BANJO BOLT (SPECIAL)	2	Z01-03-002B
5	HYDRULIC RAM (TIPPING FRAME)	1	Z01-01-AR687
5A	SEAL KIT FOR ABOVE RAM	1	Z01-Z01
6	1/2" DOWTY WASHER	12	Z01 -04-03
7	1/2" NON RETURN VALVE	1	Z01-03-017
8	1/2" x 3/8" ADAPTOR	4	Z01-06-06-08
9	1/2" x 1/2" ADAPTOR	8	Z01-06-08-08
10	1/2" MALE END Q/R COUPLING	2	Z01-15-081
11	HYD.RAM (FOR LIFT ARM)	1	Z01-01-AW
11A	SEAL KIT FOR ABOVE RAM	1	Z01-Y01
12	108" ST/90 3/8" D/W HOSE	3	Z38-R2-108-S9
13	72" ST/90 3/8" D/W HOSE	3	Z38-R2-72-S9
14	84" ST/90 3/8" D/W HOSE	1	Z38-R2-84-S9
15	24" ST/90 1/2" D/W HOSE	1	ZI 2-R2-24-S9
16	24" ST/90 3/8" D/W HOSE	1	Z38-R2-24-S9
17	12" ST/ST 3/8" D/W HOSE	2	Z38-R2-12-SS
18	9" ST/ST 3/8" D/W HOSE	1	Z38-R2-9-SS
19	48" ST/90 3/8" D/W HOSE	1	Z38-R2-48-S9
20	FILTER	1	Z01-24-08
20A	FILTER ELEMENT	1	Z01-24-08E
21	3/8" x 3/8" ADAPTOR FITTED WITH 0.06" RESTRICTOR.	1	Z01-03-40
22	1/2" MALE x 1/2" MALE x 1/2" FEMALE "T" PIECE	1	Z01-12-003
23	108" ST/90 1/2" D/W HOSE	2	ZI 2-R2-108-S9
24	HYD. RAM D/A (PULL DOWN ARM)	1	Z01-01-AW25
24A	SEAL KIT FOR ABOVE RAM	1	Z01-AW25
25	1/4" DOWTY WASHER	1	ZO 1 -04-01
26	1/4" x 3/8" ADAPTOR	1	Z01 -06-04-06
27	1/2" FEMALE x 1/2" FEMALE 90 ELBOW	1	Z01-14-018
28	3/8" MALE/FEMALE 90 ELBOW	3	Z01-14-015
29	IN LINE FLOW DIVIDER	1	Z01-03-10-A6
30	3/8" DOWTY WASHER	18	Z01-04-02
31	3/8" x 3/8" ADAPTOR	14	Z01-06-06-06
32	3/8" MALE x 3/8" MALE x 3/8" FEMALE "T" PIECE	2	Z01-12-002
33	OVER CENTRE VALVE	1	Z01-03-10-A8
34	30" ST/90 3/8" D/W HOSE	2	Z38-R2-30-S9
35	COPPER WASHER	2	Z01-04-15
36	96" ST/90 3/8" D/W HOSE	1	Z38-R2-96-SG
37	CUT & START RAM	1	Z01-01-AWH9
37A	SEAL KIT FOR ABOVE RAM	1	Z01-AWH
38	ROTARY COUPLING	1	Z01-02-ANR
39	3/8" BANJO COUPLING	1	Z01-19-062
40	3/8" SINGLE TOP BANJO BOLT	1	Z01-20-062

TANCO AUTOWRAP 1999 MODEL

CONSTANT INDEXING DRIVE ASSY

ITEMS MARKED WITH \* ARE POSITIONED AT THIS SIDE OF THE MACHINE ON "S" MODELS AND 1 OFF EACH ITEM IS REQUIRED ONLY.

ON "A" MACHINES QUANTITY REQUIRED WILL BE 2 OFF EACH ITEM AND ARE POSITIONED AT THE OPPOSITE SIDE OF THE MACHINE AS SHOWN.

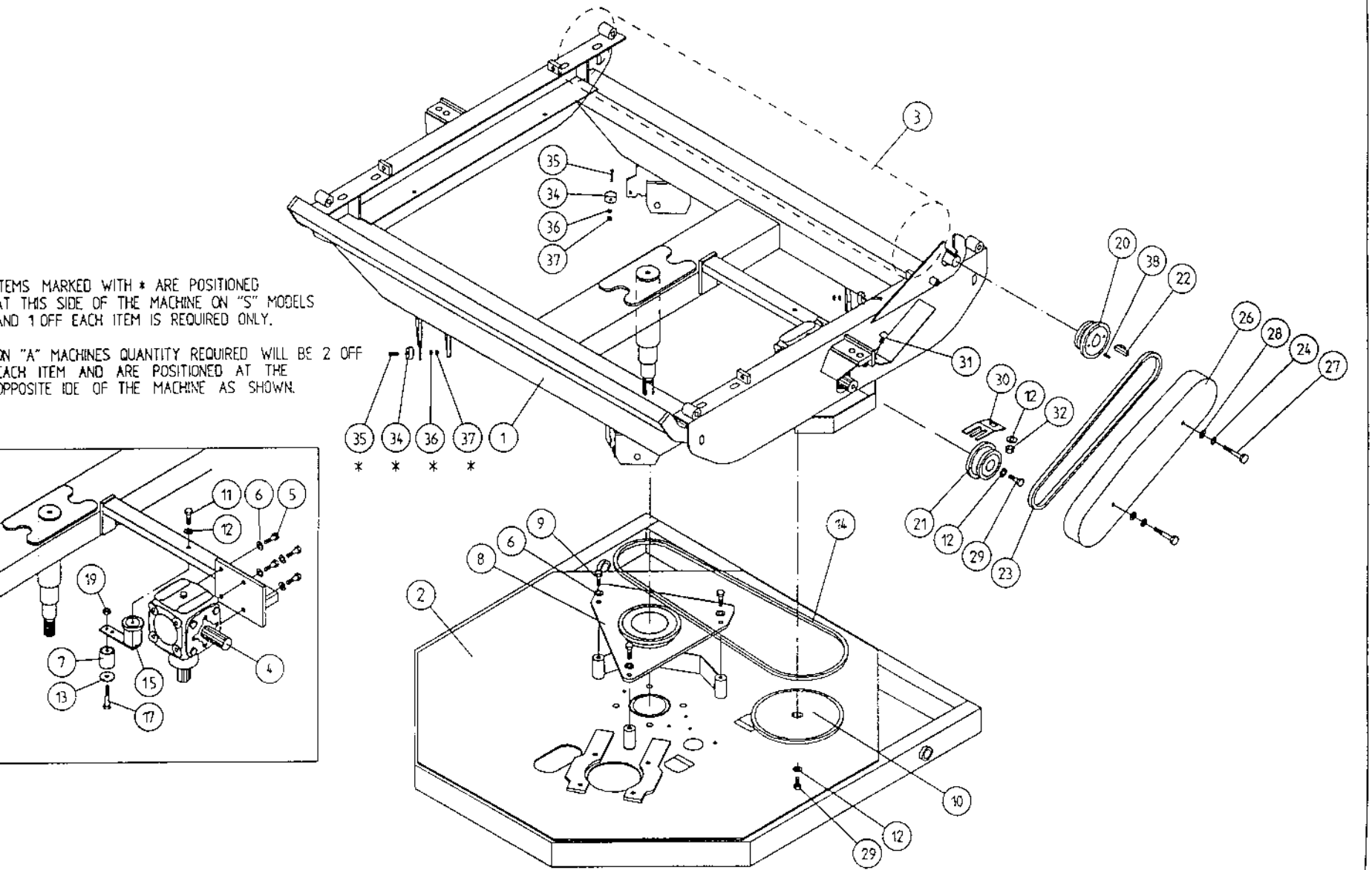



**TANCO AUTOWRAP  
CONSTANT INDEXING DRIVE ASSEMBLY**

**PARTS LIST**

ITEM NO.	DESCRIPTION	QTY.	PART-NO
1	TURNTABLE ASSY.	1	WD67-TA
2	TIPPING FRAME ASSY.	1	WD67-TF
3	DRIVE ROLLER ASSY.	1	WD66-BRD
4	GEAR BOX	1	Z01-25-300
4A	GEAR BOX SEAL KIT	1	Z01-25-300S
5	M12 HEX HD SET x 30mm LONG	4	Z26-082S
6	12mm DIA SPRING WASHER	7	Z12-02-12
7	CHAIN TENSIONER	1	WD60-CT
8	CENTRE SPROCKET ASSY 27 TOOTH	1	WD64-CSA
9	M12 HEX HD SET x 25mm LONG	3	Z26-081S
10	46 TOOTH SPROCKET	1	Z06-D64-46S
11	M10 HEX HD SET x 25mm LONG	1	Z26-0611S
12	10mm DIA SPRING WASHER	4	Z12-02-10
13	RETAINING COLLAR	1	WD623-071
14	CHAIN 3/4" PITCH X 87 PITCHES	1	Z09-AW-5
15	ROSTA TENSIONING UNIT ARM	1	Z06-454
17	M10 HEX HD BOLT x 65mm LONG	1	Z26-0671B
19	M10 LOCKNUT	1	Z23-10
20	SPROCKET DOUBLE SIMPLEX 13T/16T KEYED	1	Z06-D64-131
21	SPROCKET DOUBLE SIMPLEX 13T/16T SPLINED	1	Z06-D65-131
22	KEY 5/16"x 5/16" x 32mm LONG	1	WD623-K32
23	CHAIN 3/4" PITCH X 6 PITCHES	1	Z09-AW-3
24	1/211 DIA STAR WASHER	2	Z10-01-121
26	CHAIN GUARD	1	WD67-CGC
27	M10 HEX HD SET x 70mm LONG	2	Z26-068B
28	10mm DIA FLAT WASHER	2	Z10-02-10
29	M10 HEX HD SET x 30mm LONG	2	Z26-062S
30	CHAIN STRIPPER	1	WD67-053
31	M10 CUP SQ. SCREW x 30mm LONG	1	Z13-112
32	M10 HEX NUT	1	Z18-10
34*	MAGNET	2	D6043
35*	M6 CSK HD SET x 35mm LONG	2	Z13-132
36*	6mm DIA FLAT WASHER	2	Z11-02-06
37*	M6 LOCKNUT	2	Z23-06
38	SPIRAL PIN	2	Z03-23-062

NOTE: ON "S" MACHINES QUANTITY REQUIRED ON  
ITEMS MARKED WITH \* WILL BE 1 OFF

# TANCO AUTOWRAP 380S/580S/580A MODELS

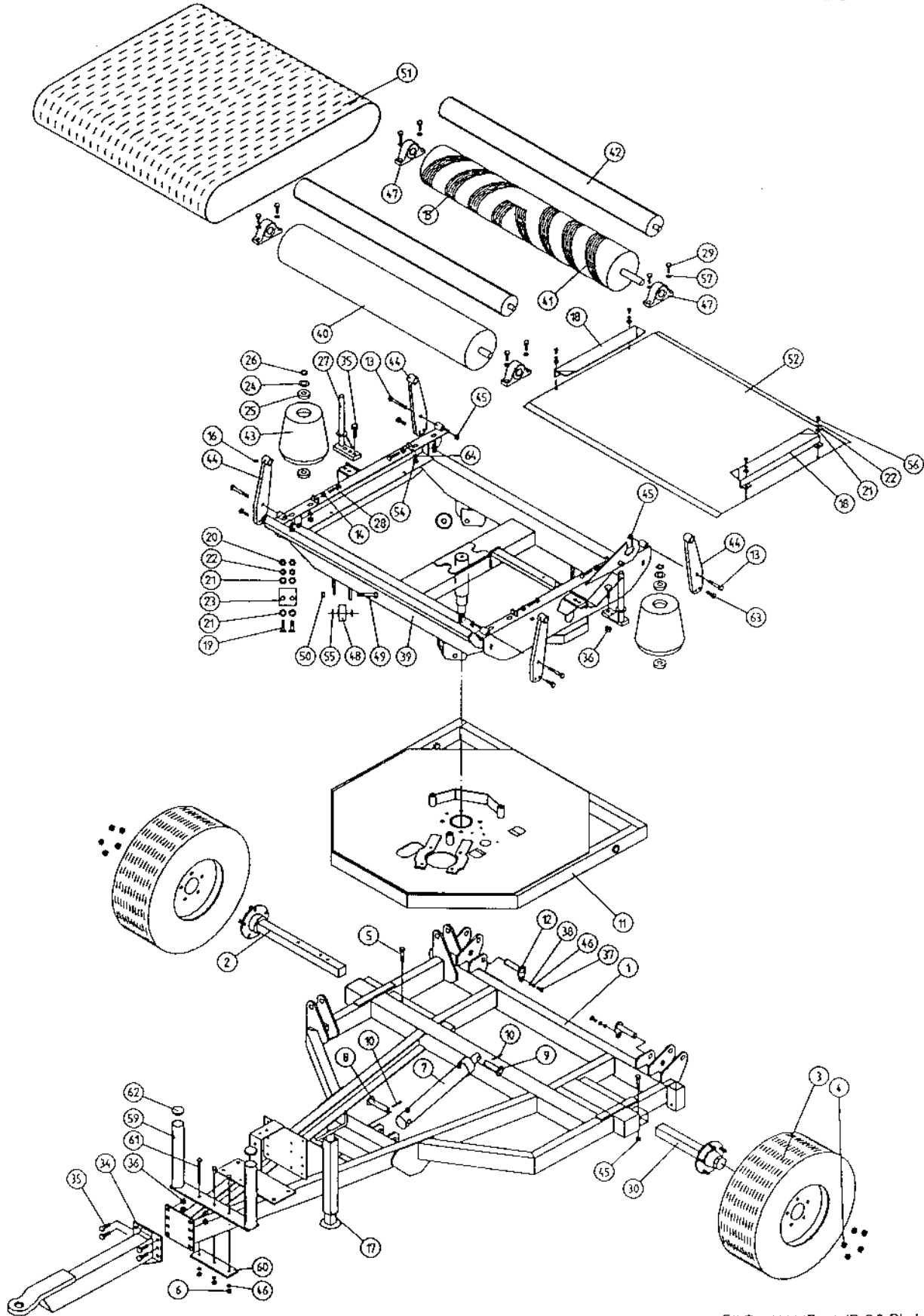

FILE NAME WD80PL44

# TANCO AUTOWRAP 380S/580S/580A MODELS TRAILED

## PARTS LIST

ITEM NO:	DESCRIPTION	QTY	PART NO.
1	CHASSIS ASSY	1	WD66-CHA
2	STUB AXLE (LONG)	1	Z04-0336
3	WHEELS (STANDARD WIDTH)	2	Z04-03
	(WIDE)		Z04-04
4	WHEELS NUTS	10	M22AWNA
5	BISSSEL PIN	2	Z03-22-AW82
6	M10 HEX NUT	3	Z18-10
7	HYDRAULIC RAM	1	Z01-01-AR687
8	RAM BOTTOM PIVOT PIN	1	Z03-02-330
9	RAM TOP PIVOT PIN	1	Z03-03-50
10	2" X 1/4" SPLIT PIN	2	Z03-21-29
11	TIPPING FRAME ASSEMBLY	1	WD64-TF
12	TIPPING FRAME PIVOT PIN C/W GREASE NIPPLE	2	Z03-01-9055
			Z39-60
13	M12 HEX HD BOLT X 80MM LONG	4	Z26-0901B
14	M12 HEX NUT	4	Z16-12
15	GRIP FACE KIT	2	Z05-02-AW49
16	1/8" B.S.P. ST GREASE NIPPLE	4	Z39-60
17	SCREW JACK ASSEMBLY (WELDED ON)	1	WD60-JA
18	BELT GUIDE ASSEMBLY	2	WD66-BG
19	M8 HEX HD SETS X 20MM LONG	4	Z26-039S
20	M8 HEX NUTS	14	Z18-08
21	8MM DIA FLAT WASHERS (MUD FLAP)	8	Z11-02-081
22	8MM DIA SPRING WASHERS	12	Z12-02-08
23	SCRAPER	2	WD60-711
24	THRUST WASHER	2	WD60-292
25	BEARING (25MM I.D.)	4	Z06-AWRB-93
26	CIRCLIP	2	Z28-525
27	END ROLLER MOUNTING BRACKET	2	WD66-ERH
28	M12 HEX HD SET X 60MM LONG	4	Z26-088S
29	M14 HEX HD SET X 55MM LONG	8	Z26-105S
30	STUB AXLE (SHORT)	1	Z04-032
31	INNER BEARINGS	2	M22AB-209
32	OUTER BEARINGS	2	M22AB-206
33	4MM 'R' CLIP	2	Z36-02
34	RING HITCH ASSY (LONG)	1	WD65-HIT
35	M16 HEX HD SET X 50MM LONG	6	Z2G-124S
36	M16 LOCKNUTS	6	Z23-16
37	M10 HEX HD SET X 25MM LONG	2	Z26-061S
38	10MM DIA MACHINED FLAT WASHER	2	Z11-02-10
39	TURN TABLE ASSY	1	WD66-TA
40	BELT ROLLER ASSY IDLER	1	WD66-BRI
41	BELT ROLLER ASSY DRIVER	1	WD66-BRD
42	SMALL ROLLER ASSY	2	WD66-SMR
43	SIDE ROLLER	2	Z06-AWR
44	ROLLER MOUNTING BRACKET	4	WD66-RMB
45	M12 LOCKNUTS	8	Z23-12
46	10MM DIA SPRING WASHER	5	Z12-02-10
47	1 1/4" PILLOW BLOCK BEARING C/W CAM LOCK COLLAR	4	Z06-485
48	SUPPORT WHEELS (4" DIA)	4	Z06-466W
49	AXLE ASSY C/W GREASE NIPPLE	4	Z03-22-AW/AX
			Z39-60
			Z23-20
50	M20 LOCKNUTS	4	Z23-20
51	1200 WIDE X 2475MM LONG X 1/4" FLAT BELT	1	Z05-02AW96
52	TURN TABLE COVER PLATE	1	WD66-043
54	M14 HEX NUT	4	Z18-14
55	SPACER	8	WD60-198
56	M8 HEX HD SET X 30MM LONG	4	Z26-041S
57	14MM DIA FLAT WASHER	8	Z11-02-14
58	M12 HEX HD SET X 30MM LONG	2	Z26-082S
59	FILM TRANSPORT BRACKET	1	WD60-FTB1
60	CLAMPING PLATE	1	WD60-933
61	M10 HEX HD BOLT X 140MM LONG	3	Z26-0726S
62	PLASTIC CAP	2	Z32-08
63	M12 HEX HD SET X 40MM LONG	4	Z26-084S
64	14MM DIA SPRING WASHER	4	Z12-02-14

# TANCO AUTOWRAP TURNTABLE CHAIN DRIVE ASSEMBLY

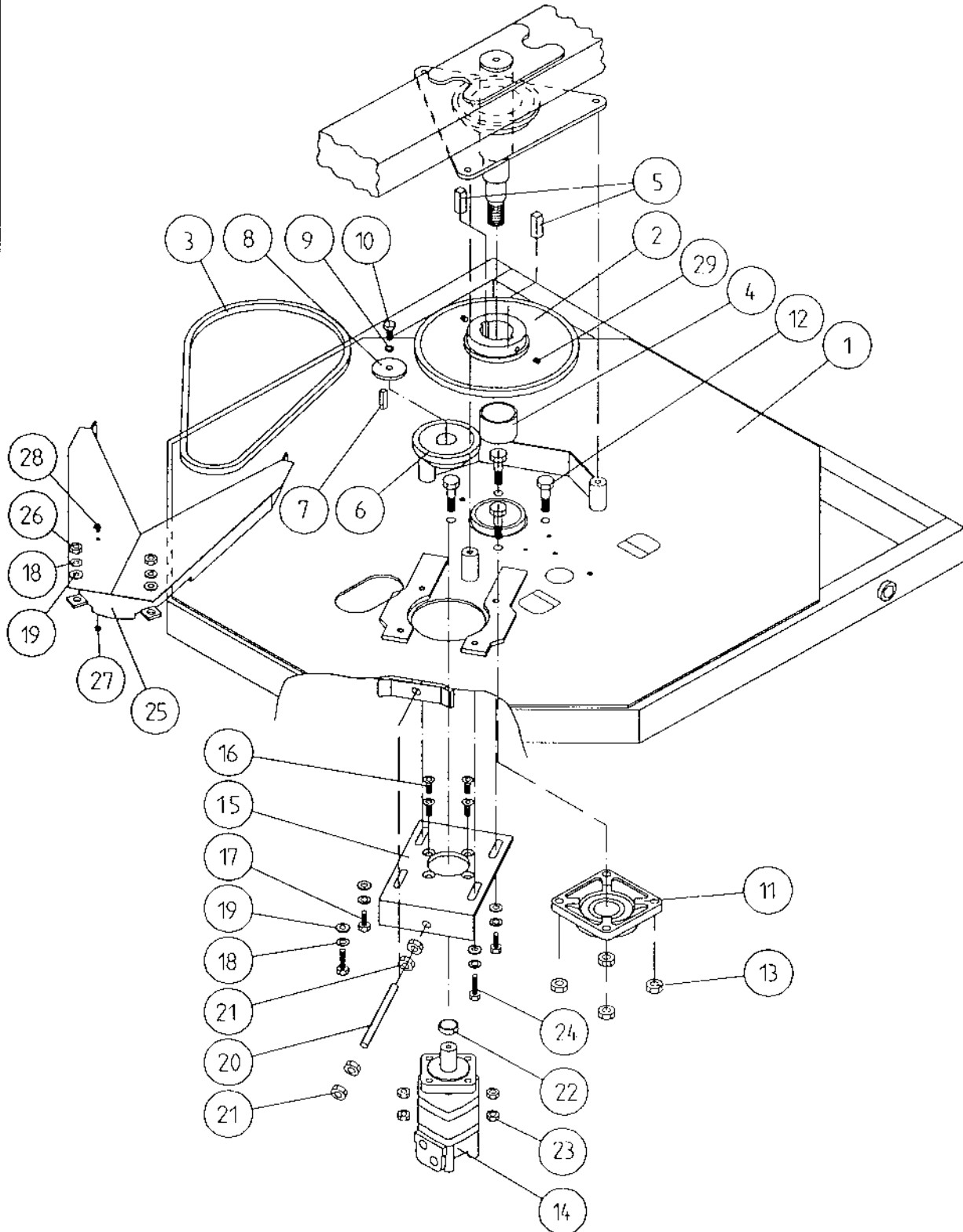

FILE NAME: WD66 PL9

**TANCO AUTOWRAP  
TURNTABLE CHAIN DRIVE ASSEMBLY**

**PARTS LIST**

ITEM NO	DESCRIPTION	QTY	PAPT NO
1	TIPPING FRAME ASSY	1	WD67-TF
2	38 TOOTH x 1" PITCH SPROCKET	1	Z06-D64-38
3	CHAIN 1" PITCH x 54 PITCHES	1	Z09-AW6
4	SPINDLE SPACER	1	WD64-040
5	KEY 5/8" SQ x 50mm LONG	2	WD64-052
6	15 TOOTH x 1" PITCH SPROCKET	1	Z06-I60-046
7	KEY 5/16" SQ x 45mm LONG	1	WD64-053
8	LOCKING COLLAR	1	WD623-071
9	10mm DIA SPRING WASHER	1	Z12-02-10
10	3/8" UNC HEX HD SET x 1" LONG	1	Z27-023S
11	2" DIA FLANGE BEARING		
	C/W CAM LOCK COLLAR	1	Z06-49EC
12	5/8" UNF HEX HD SET x 2" LONG	4	Z31B-064
13	5/8" UNF LOCKNUT	4	Z20-10
14	HYDRAULIC MOTOR	1	Z01-02-RF200
15	HYDRAULIC MOTOR MOUNTING PLATE	1	WD64-001
16	M12 x 50mm ALLEN HD O/S SCREW	4	Z13-5-12X50
17	M12 HEX HD SET x 30mm LONG	4	Z26-082S
18	12mm DIA SPRING WASHER	4	Z12-02-12
19	12mm DIA FLAT WASHER	4	Z10-02-12
20	M16 THREADED BAR x 150mm LONG	1	WD64-038
21	M16 HEX NUT	4	Z18-16
22	SPACER	1	Wi60-093
23	M12 LOCKNUTS	4	Z23-12
24	M12 HEX HD SET x 50mm LONG	2	Z26-086S
25	DRIVE CHAIN GUARD	2	WD66-DCG
26	M12 HEX NUT	2	Z18-12
27	M6 HEX NUT	1	Z18-06
28	M6 90 DEGREE GREASE NIPPLE	1	Z39-65
29	M12 GRUB SCREW x 16mm LONG	2	Z28-012

TANCO AUTOWRAP 380S/580S/580A MODELS  
LIFT ARM ASSEMBLY

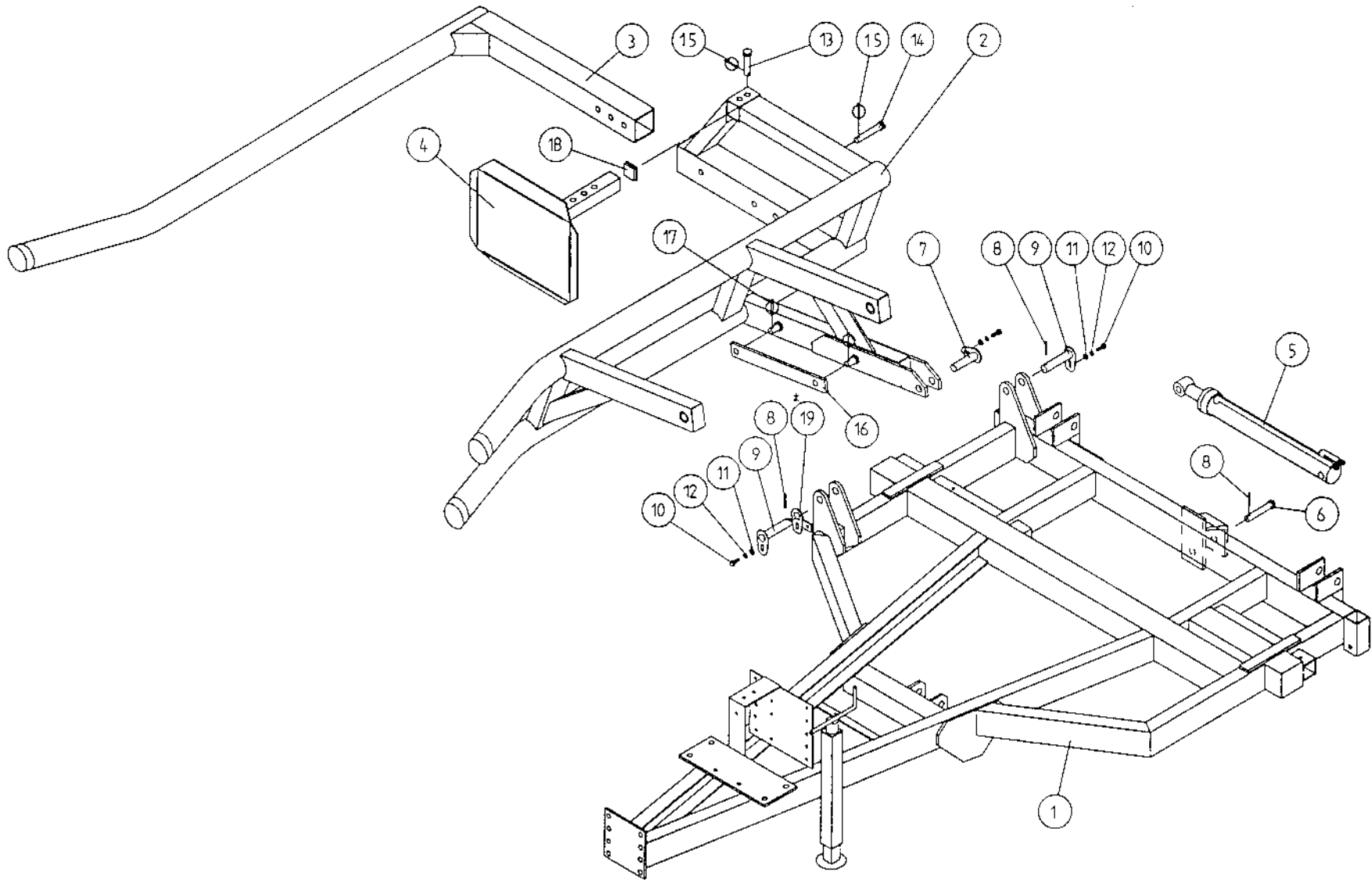

**TANCO AUTOWRAP 380S / 580S / 580A MODELS  
LIFT ARM AND CHASSIS**

**PARTS LIST**

TEM NO	DESCRIPTION	QTY	PART NO.
1	CHASSIS ASSEMBLY	1	WD67-CHA
2	LIFT ARM ASSEMBLY	1	WD60-LA
3	ADJUSTABLE OUTER ARM ASSEMBLY	1	WD60-LAAA
4	ADJUSTABLE BALE STOP	1	WD610-LAS
5	HYDRAULIC RAM (LIFT ARM)	1	Z01-01-AW
6	RAM BOTTOM PIVOT PIN	1	Z03-02-330
7	RAM TOP PIVOT PIN	1	Z03-01-905A
8	2" X 1/4" SPLIT PINS	3	Z03-21-29
9	LIFT ARM PIVOT C/W GREASE NIPPLE	2	Z03-01-905
10	M10 HEX HD SET X 25MM LONG (TUFLOCK)	3	Z26-061S
11	10MM DIA MACHINED FLAT WASHER	3	Z11-02-10
12	10MM DIA SPRING WASHERD	3	Z12-02-10
13	SPAREX PIN	1	Z03-04-73
14	SPAREX PIN	1	Z03-04-77
15	7/16" DIA LINCH PINS	2	Z03-22-06
16	SAFETY SUPPORT BAR	1	WD60-319
17	6MM DIA LINCH PIN	2	Z03-22-03
18	PLASTIC CAP	1	Z32-10
* 19	LIFT ARM SENSOR MOUNTING BRACKET	1	WD610-LSM
	* ON 'A' MODELS ONLY		

# TANCO AUTOWRAP 580S/580A MODELS FILM DISPENSER SYSTEM

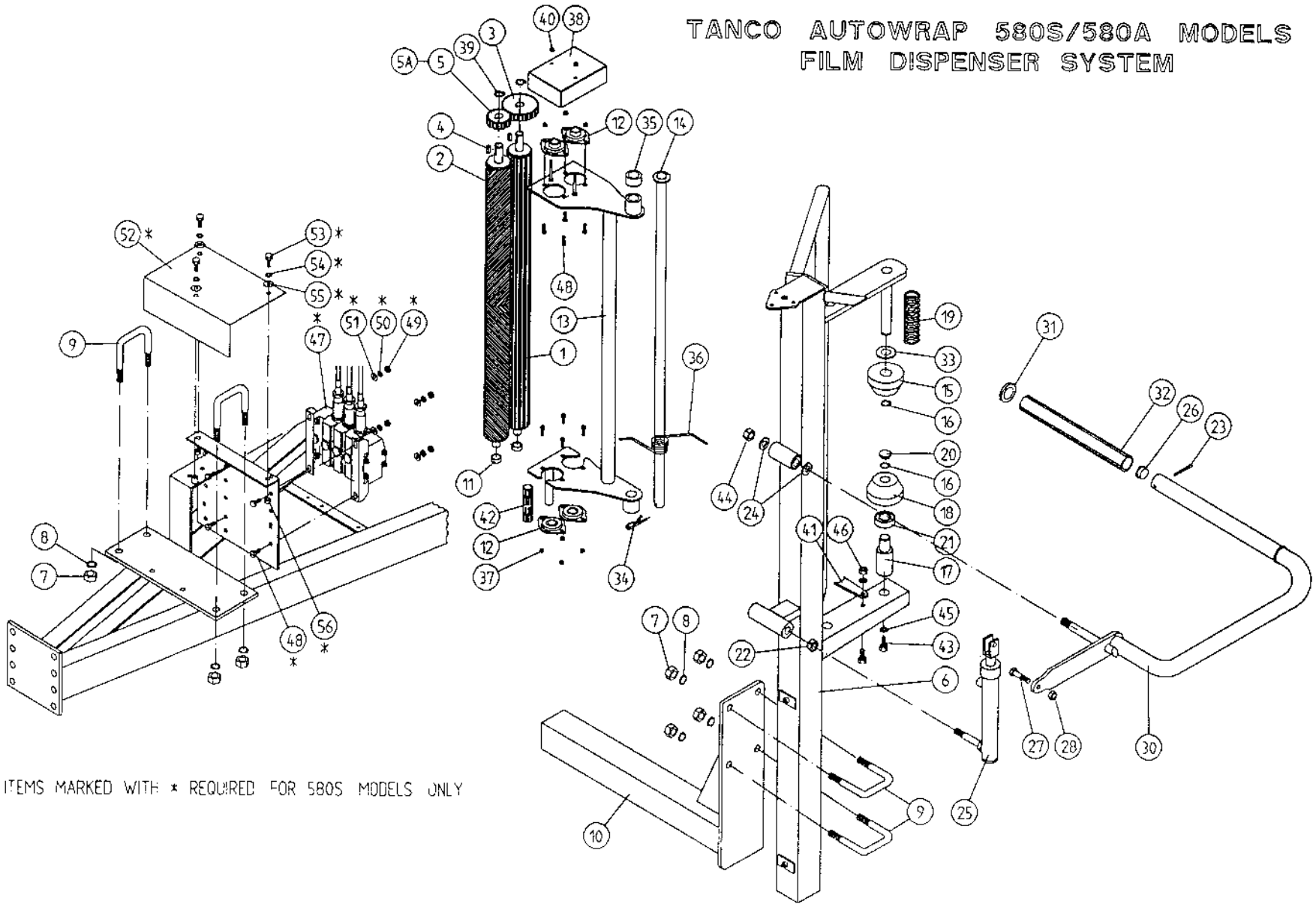

ITEMS MARKED WITH \* REQUIRED FOR 580S MODELS ONLY



**TANCO AUTOWRAP 580S/580A MODELS  
FILM DISPENSING SYSTEM  
PARTS LIST**

ITEM NO:	DESCRIPTION:	QTY:	PART NO:
1	INNER ROLLER ASSY	1	D617-IRA1
2	OUTER ROLLER ASSY	1	D617-ORA
3	60 T GEAR	1	D617-G60
4	6mm SQ. KEY STEEL x 20mm LONG	2	WD67-KS20
5	39T GEAR - 55% STRETCH	1	D617-G39
5A	35T GEAR - 70% STRETCH	1	D617-G35
6	DISPENSER MAST	1	WD617-DM
7	M16 HEX NUT	8	Z18-16
8	16mm SPRING WASHER	8	Z12-02-16
9	80mm M16 'U' BOLTS	4	Z35-52
10	DISPENSER MAST MOUNTING BRACKET	1	WD67-DMM
11	3/4" x 10mm SPACER	2	D617-026
12	RHP SLF20A BEARING	4	Z06-17
13	FILM DISPENSER MAIN FRAME	1	WD617-FDMS
14	PIVOT PIN	1	WD617-PP1
15	TOP CONE	1	WD90-012
16	CIRCLIP	2	Z28-525
17	FILM SPOOL LOWER	1	WD617-013
18	BOTTOM CONE	1	WD90-013
19	SPRING	1	Z07-07
20	PLASTIC CAP 1 1/4" DIA	1	Z39-60
21	BEARING	1	Z06-AWRB
22	M16 LOCKNUT	2	Z23-16
23	1/4" X 2" SPLIT PIN	2	Z01-23-29
24	16mm DIA FLAT WASHER	2	Z10-02-16
25	HYDRAULIC RAM (PULL DOWN)	1	Z01-01-AW25
26	1" G.B. PLASTIC CAP	1	Z32-14
27	M12 X 50 HEX SET	1	Z26-086S
28	M12 LOCKNUT	1	Z23-12
29	12mm DIA FLAT WASHER	1	Z12-02-12
30	FILM PULL DOWN ARM ASSEMBLY	1	WD617-FPDA
31	RETAINING WASHER	1	WD60-859
32	ROLLER	1	WD60-866
33	1" DIA FLAT WASHETR	1	Z10-02-30
34	6mm "R" CLIP	1	Z36-03
35	PLATED COLLAR	1	WD617-025
36	TORSION SPRING	1	Z07-04
37	M8 LOCKNUT	2	Z23-06
38	DISPENSER GEARBOX COVER	1	WD617-GC1
39	20mm EXTERNAL CIRCLIP	2	Z28-520
40	M6 LOCKNUT	2	Z23-06
41	PLATE LATCH	1	WD617-019
42	PLASTIC HAND GRIP	1	Z32-16
43	M10 x 25mm SET	2	Z26-0611S
44	M20 x 2.5mm PITCH LOCKNUT	1	Z23-20
45	10mm DIA SPRING WASHER	2	Z12-02-10
46	M10 HEX NUT	1	Z18-10
47*	3 BANK SPOOL VALVE (DIN)	1	Z01-03-018D
48*	M8 x 20mm HEX SET	4+8	Z26-039S
49*	M8 HEX NUT	4	Z18-08
50*	8mm DIA SPRING WASHER	4	Z12-02-08
51*	8mm DIA FLAT WASHER	4	Z11-02-081
52*	VALVE COVER PLATE	1	WD605M-19
53*	M10 x 20 HEX SET	3	Z26-060S
54*	10mm DIA SPRING WASHER	3	Z12-02-10
55*	10mm DIA MUD FLAP WASHER	3	Z11-02-061
56*	M10 HEX NUT	3	Z18-10

\* DENOTES ITEMS REQUIRED FOR 580S MODEL ONLY

TANCO AUTOWRAP  
HYDRAULIC CUT AND START  
MAIN ASSEMBLY

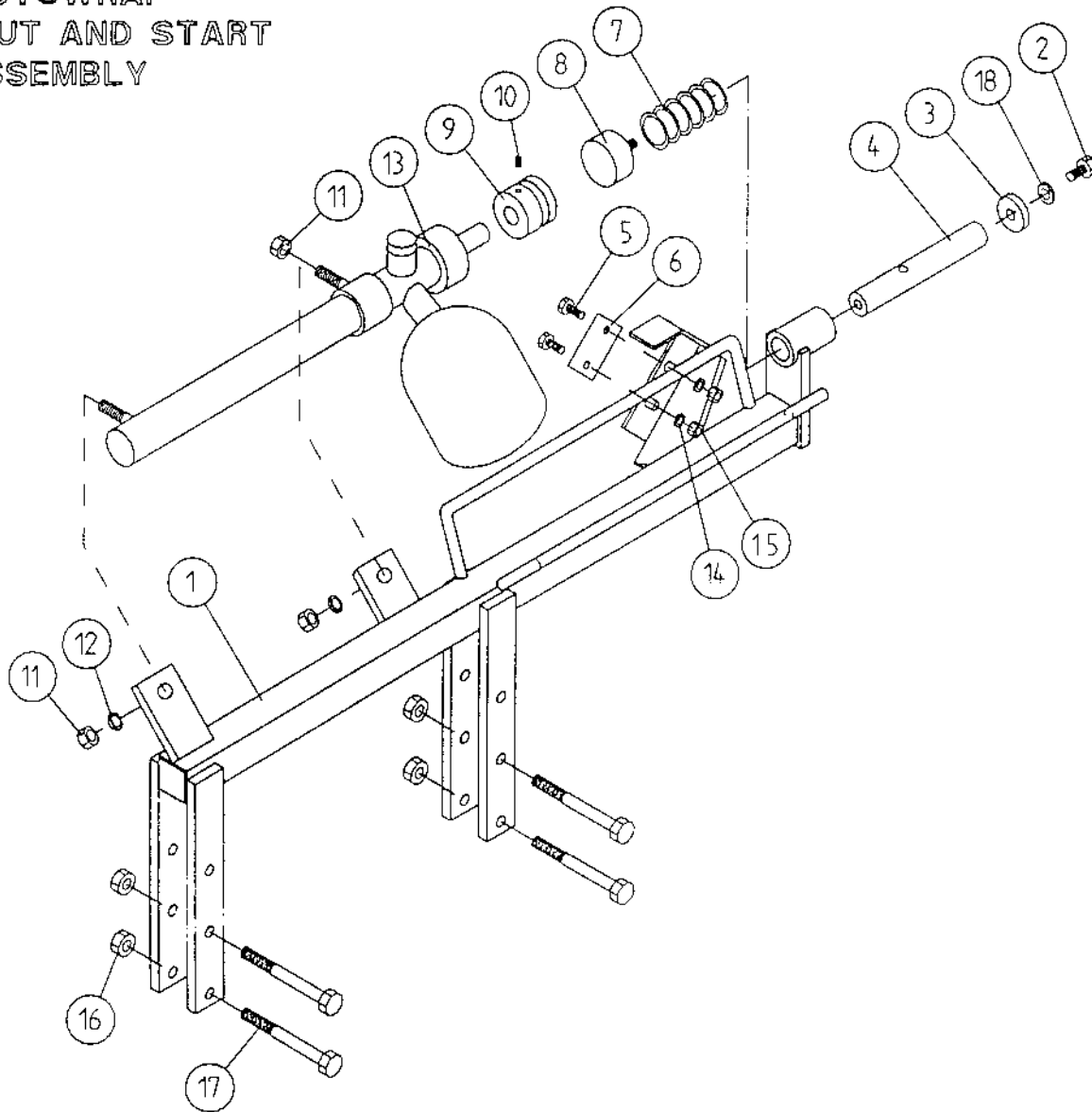

FILE NAME WD80PL86

**TANCO AUTOWRAP  
HYDRAULIC CUT AND START UNIT  
PARTS LIST**

ITEM NO.	DESCRIPTION	QTY	PART NO.
1	HYDRAULIC CUT AND START MAIN FRAME	1	WD605H-MF
2	M10 x 25 HEX SET	1	Z26-061S
3	LOCKING COLLAR	1	Wi60-090
4	GRIPPER ROD	1	WD605H-13
5	H6 X 25 HEX SET	1	Z26-0405
6	BLADE	1	605-104
7	SPRING	1	Z07-49
8	GRIPPER PAD (RUBBER)	1	Z40-28
9	GRIPPER PAD	1	WD605H-15
10	M8 X 10 GRUB SCREW	1	Z28-008
11	M 14 HEX NUT	3	Z18-14
12	14MM SPRING WASHER	2	Z12-02-14
13	CUT & START HYDRAULIC RAM ACCUMULATOR	1	Z01-01-AWH
14	8MM FLAT WASHER	2	Z11-02-08
15	M8 LOCK NUT	2	Z23-08
16	M10 LOCK NUT	4	Z23-010
17	M10 X 75 HEX BOLT	4	Z26-069B
18	10mm DIA SPRING WASHER	1	Z12-02-10

## TANCO AUTOWRAP CUT AND START SENSOR AND MAGNET MOUNTING BRACKETS

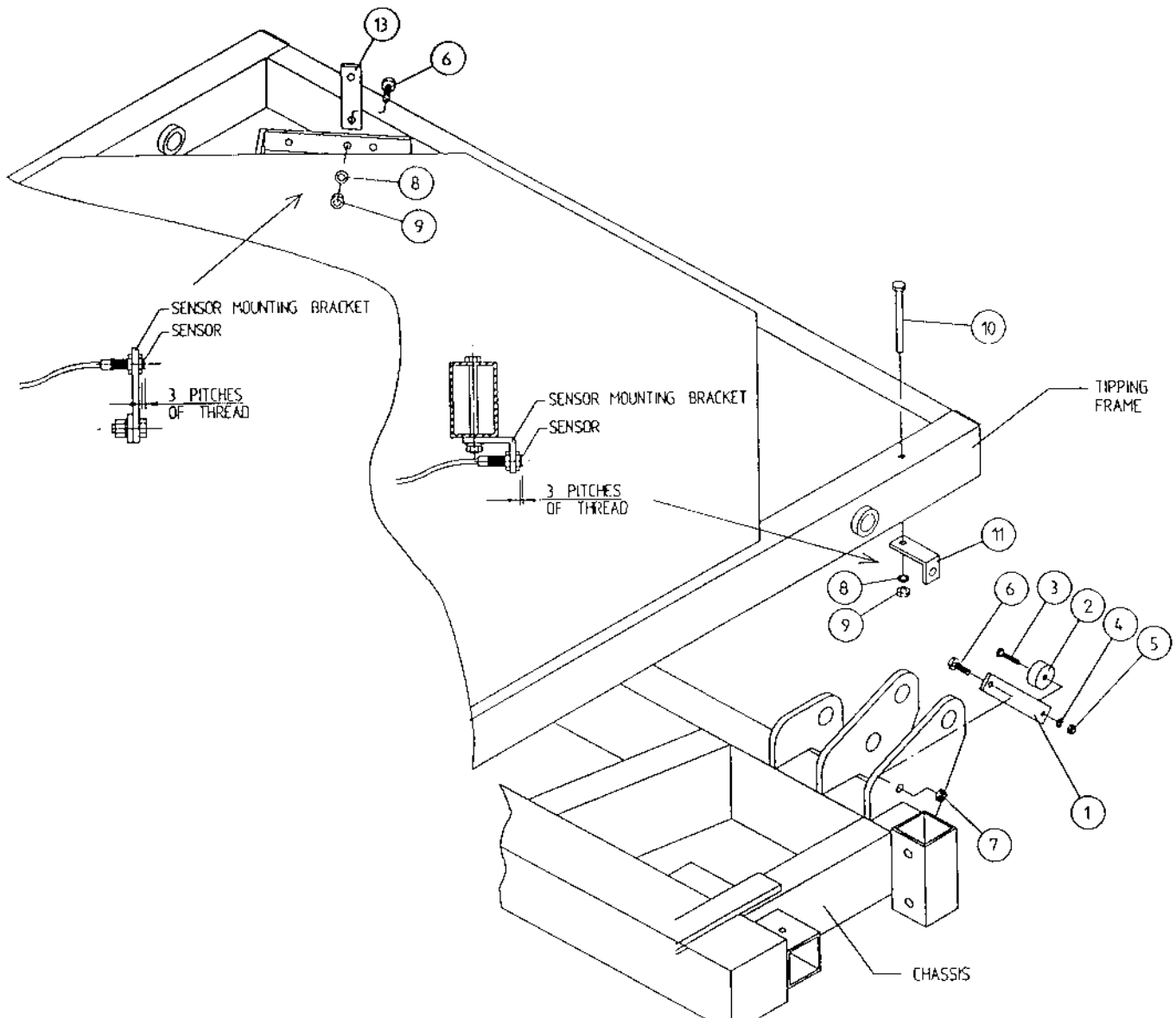

### PARTS LIST

ITEM NO	DESCRIPTION	QTY	PART NO.
1	MAGNET MOUNTING BRACKET	1	WD605-165
2	MAGNET	1	D6034
3	M6 HEX HD. SET x 30mm LONG	1	Z26-022S
4	6mm DIA FLAT WASHER	1	Z12-02-06
5	M6 LOCKNUT	1	Z23-06
6	M8 HEX HD. SET x 25mm LONG	2	Z26-040S
7	M8 LOCKNUT (NYLOCK)	1	Z23-08
8	8mm DIA SPRING WASHER	2	Z12-02-08
9	M8 HEX NUT	2	Z18-08
10	M8 HEX HD. SET x 100mm LONG	1	Z26-057S
11	SENSOR MOUNTING BRACKET	1	WD605-58
12	SENSOR MOUNTING FLAT	1	WD605-164

WD64 PL41

TANCO AUTOWRAP

TURNTABLE LOCKING ARRANGEMENT

PARTS LIST

ITEM	DESCRIPTION	QTY	PART NO
1	UNDERSIDE OF TIPPING FRAME	1	WD64-TF
2	TURNTABLE CENTRE SHAFT	1	WD64-002
3	SPINDLE SPACER	1	WD67-SS
4	1 1/4" UNC HEX NUT	1	Z18-300
5	M8 GRUB SCREW X 6MM LONG	1	Z28-007

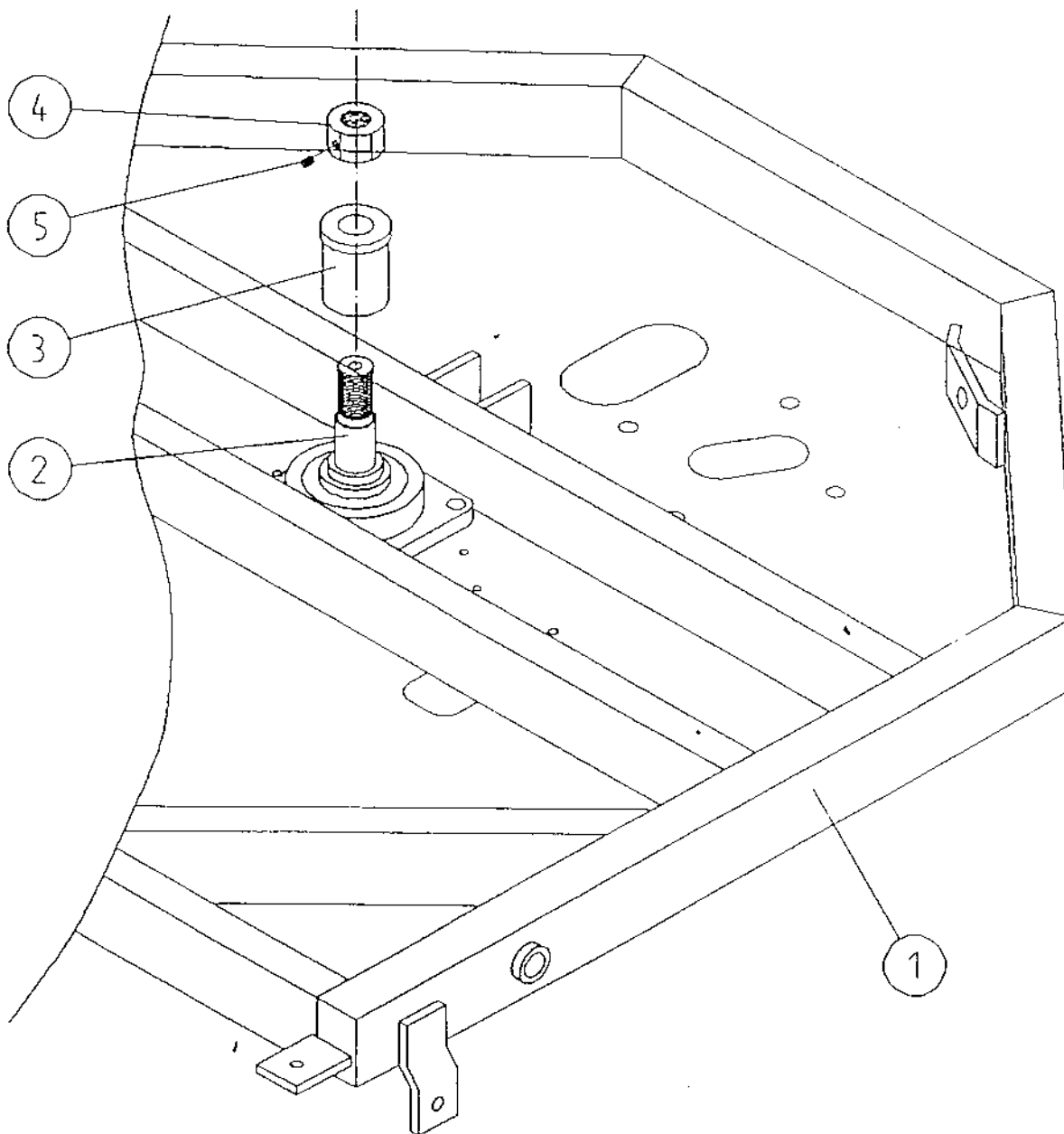

# TANCO AUTOWAP HYDRAULIC BALE RAMP

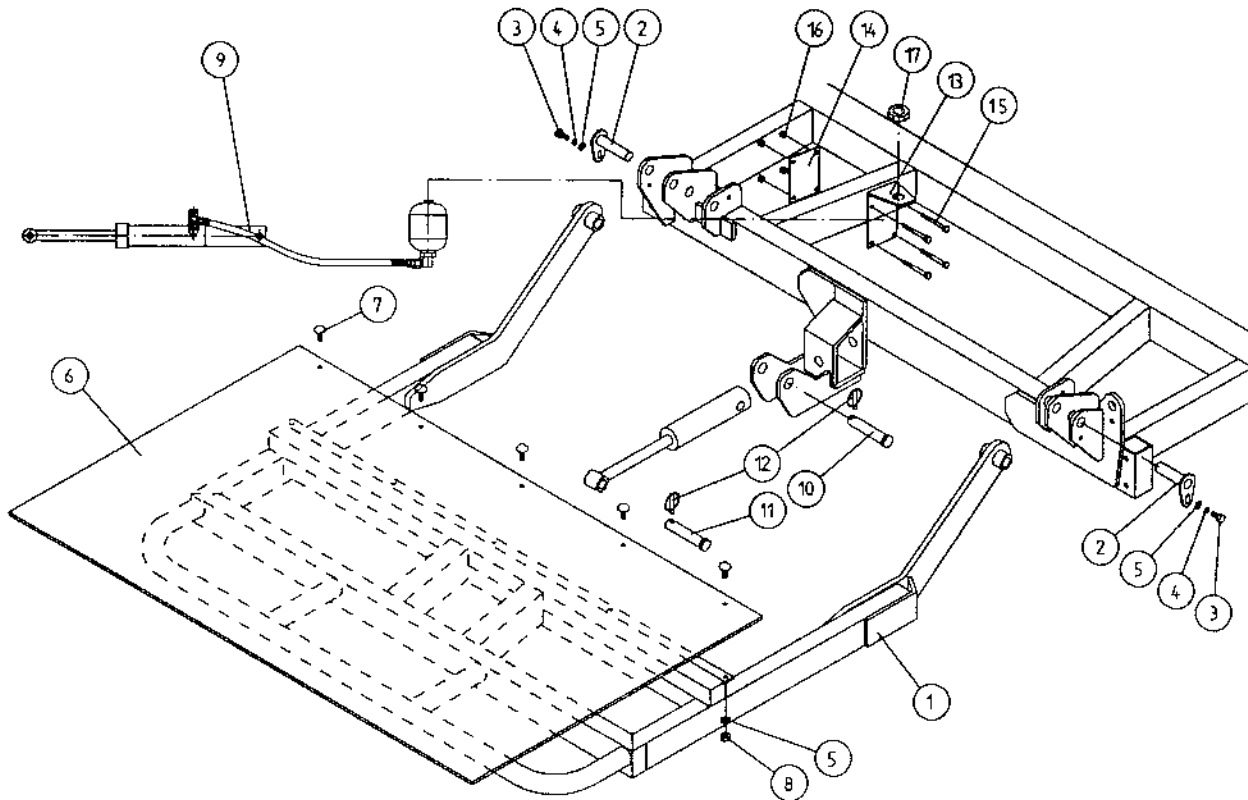

## INSTRUCTIONS FOR RECHARGING AND REDUCING PRESSURE IN HYDRAULIC BALE RAMP CYLINDER

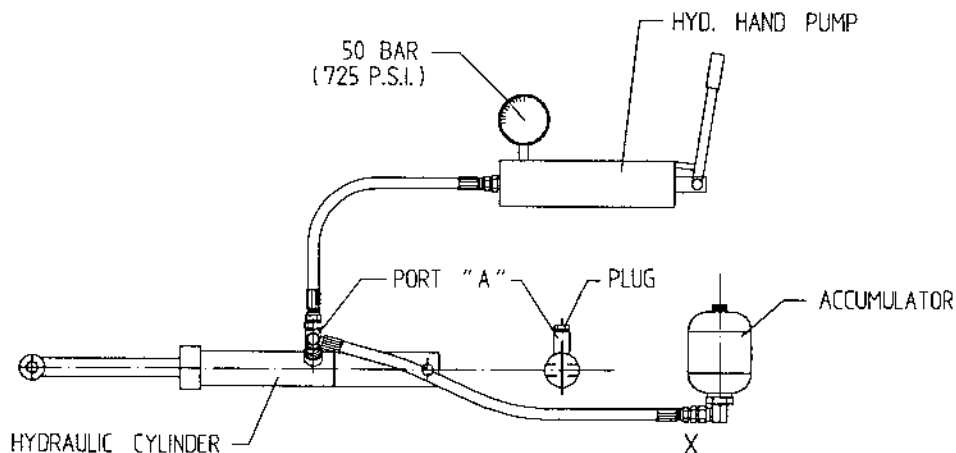

### TO RECHARGE CYLINDER

1. REMOVE PLUG FROM PORT "A".
2. CONNECT HOSE FROM HYD. HAND PUMP TO PORT "A".
3. CHARGE CYLINDER TO A PRESSURE OF 50 BAR (725 P.S.I.)
4. BLEED AIR FROM SYSTEM BY SLACKENING HOSE CONNECTION AT BASE OF ACCUMULATOR MARKED X. RETIGHTEN CONNECTION.
5. REMOVE PUMP HOSE FROM PORT "A" AND REFIT PLUG.

### TO REDUCE PRESSURE IN CYLINDER

1. SLACKEN CONNECTION ON HOSE END JUST ENOUGH TO ALLOW OIL TO BLEED OUT SLOWLY.
2. RETIGHTEN CONNECTION AND CHECK OPERATION OF BALE RAMP AS DETAILED IN FIG. 1.
3. REPEAT PROCEDURE UNTIL OPERATION OF RAMP IS CORRECT.

WD64-PL25

TANCO AUTOWRAP MODEL  
HYDRAULIC BALE RAMP

PARTS LIST

ITEM	DESCRIPTION:	QTY:	PART NO:
1	HYDRAULIC BALE RAMP ASSY	1	WD65-HBRF
2	RAMP MAIN PIVOT PIN C/W GREASE NIPPLE	2	Z03-01-905
3	M10 HEX HD SET X 20mm LONG TUFLOCK	2	Z26-060ST
4	10mm DIA MACHINED FLAT WASHER	2	Z11-02-10
5	10mm DIA SPRING WASHER	12	Z12-02-10
6	BALE MAT	1	Z05-02-BRH
7	M10 X 30mm LONG CUP HD.SQ BOLTS	5	Z13-112
8	M10 HEX NUTS	5	Z18-10
9	HYDRAULIC RAM C/W ACCUMULATOR	1	Z01-01-AWD
10	SPAREX PIN	1	Z03-04-74
11	SPAREX PIN	1	Z03-04-73
12	7/16" DIA LINCH PIN	2	Z03-22-06
13	ACCUMULATOR MOUNTING PLATE	1	WD65-AMP
14	CLAMPING PLATE	1	WD65-231
15	M8 HEX HD BOLT X 80mm LONG	4	Z26-050B
16	M8 LOCKNUT	4	Z23-08
17	M28 X 1.5 PITCH HEX NUT	1	Z18-28

TANCO AUTOWRAP TRAILED MODELS  
LIGHTING KIT

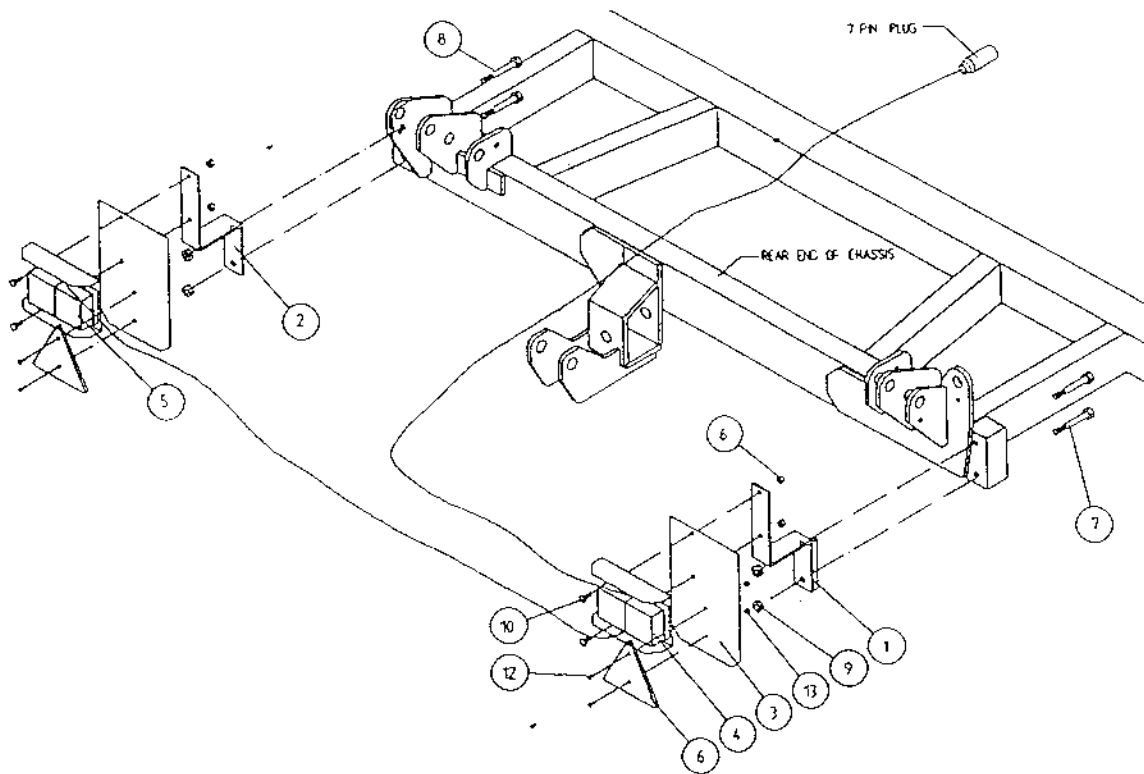

ITEM NO	DESCRIPTION	QTY	PART-NO.
1.	LIGHT MOUNTING BRACKET RHS	1	WD60-LMB
2.	LIGHT MOUNTING BRACKET LHS	1	WD60-899
3.	LIGHT MOUNTING PLATE	2	WD60-898
4.	LIGHT CLUSTER RHS	1	Z05-30R
5.	LIGHT CLUSTER LHS	1	Z05-30L
6.	TRIANGULAR REFLECTOR	2	Z04-62
7.	M12 HEX HD BOLT X 100 LONG	2	Z26-092B
8.	M12 HEX HD BOLT X 90 LONG	2	Z06-091B
9.	M12 LOCKNUT	4	Z23-12
10.	M8 HEX HD SET X 20 LONG	4	Z26-39S
11.	M8 LOCKNUT	4	Z23-08
12.	M6 CHEESE HEAD SET X 20 LONG	4	Z13-15
13.	M6 LOCKNUT	4	Z23-06



**TANCO AUTOWRAP 580A MODEL  
VALVE/JUNCTION BOX/FILTER & DIVERTER VALVE  
MOUNTING BRACKET ASSEMBLY**

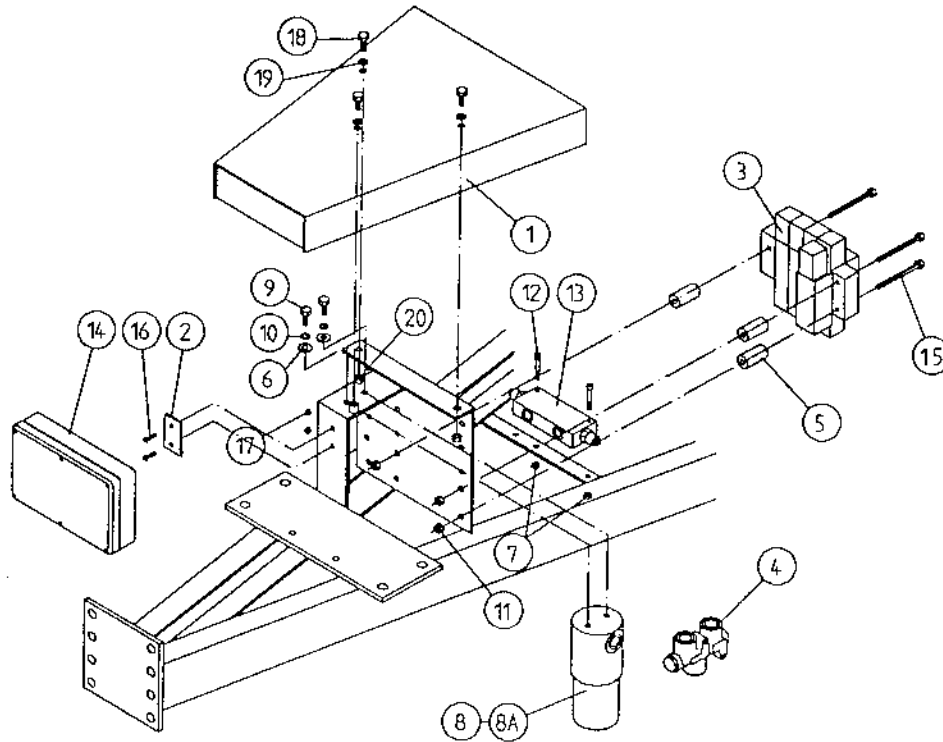

**PARTS LIST**

ITEM NO:	DESCRIPTION:	QTY:	PART NO:
1	VALVE COVER PLATE ASSY	1	WD67-VCP
2	JUNCTION BOX MOUNTING BRACKET	1	ZLY-BRK
3	4 BANK SOLENOID VALVE	1	Z01-03-A550
4	FLOW DIVIDER	1	Z01-03-10-A6
5	SPACER	3	WD67-100
6	8MM DIA MUD FLAP WASHER	2	Z11-02-081
7	M6 LOCKNUT (NYLOCK)	2	Z32-06
8	OIL FILTER	1	Z01-24-08
8A	OIL FILTER ELEMENT	1	Z01-24-08E
9	M8 HEX HD SET X 25MM	2	Z26-040S
10	8MM DIA SPRING WASHER	2	Z12-02-08
11	M8 LOCKNUTS	3	Z23-08
12	M6 ALLEN HD SOCKET SCREW x 45mm	2	Z13-020-50
13	OVER-CENTRE VALVE	1	Z01-03-10-A8
14	JUNCTION BOX	1	ZLY-580A
15	M8 x 100mm HEX SET	3	Z26-057S
16	M4 CSK' SOCKET SCREW x 20mm	2	ZLY-S
17	M4 LOCKNUT	2	Z23-04
18	M10 x 20mm HEX SET	3	Z26-060S
19	10mm DIA SPRING WASHER	3	Z12-02-10
20	M10 HEX NUT	2	Z18-10

## TANCO AUTOWRAP 580A MODEL ELECTRIC COMPONENTS

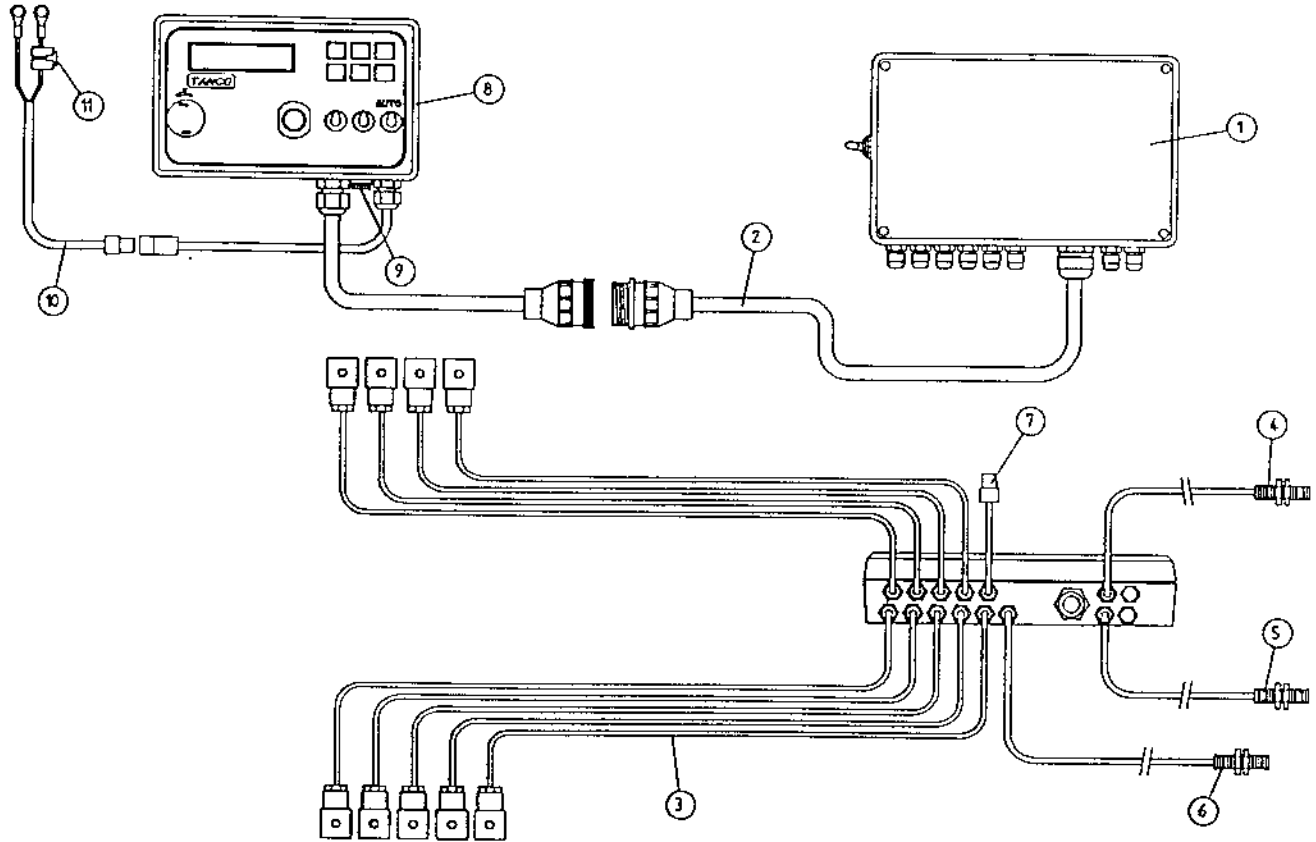

### PARTS LIST

ITEM No.	DESCRIPTION	QTY.	PART No.
1	JUNCTION BOX	1	ZLY-580A
2	24 CORE INTERCONNECTING LEAD C/W CONNECTORS	1	ZLY-P02
3	LOOM FOR VALVE C/W HERSCHMAN	9	ZLY-P03
4	LIFT ARM SENSOR	1	ZLY-P04
5	TIP SENSOR	1	ZLY-P05
6	ROTATE SENSOR	1	ZLY-P06
7	SYSTEM PRESSURE LEAD	1	ZLY-P07
8	CONTROL BOX (580A)	1	D606C-A
9	FUSE 16AMP	1	ZLY-P09
10	MAIN BATTERY LEAD	1	ZLY-P10
11	INLINE FUSE	1	ZLY-P11

TANCO AUTOWRAP 580S MODEL  
ELECTRIC COMPONENTS

2003A

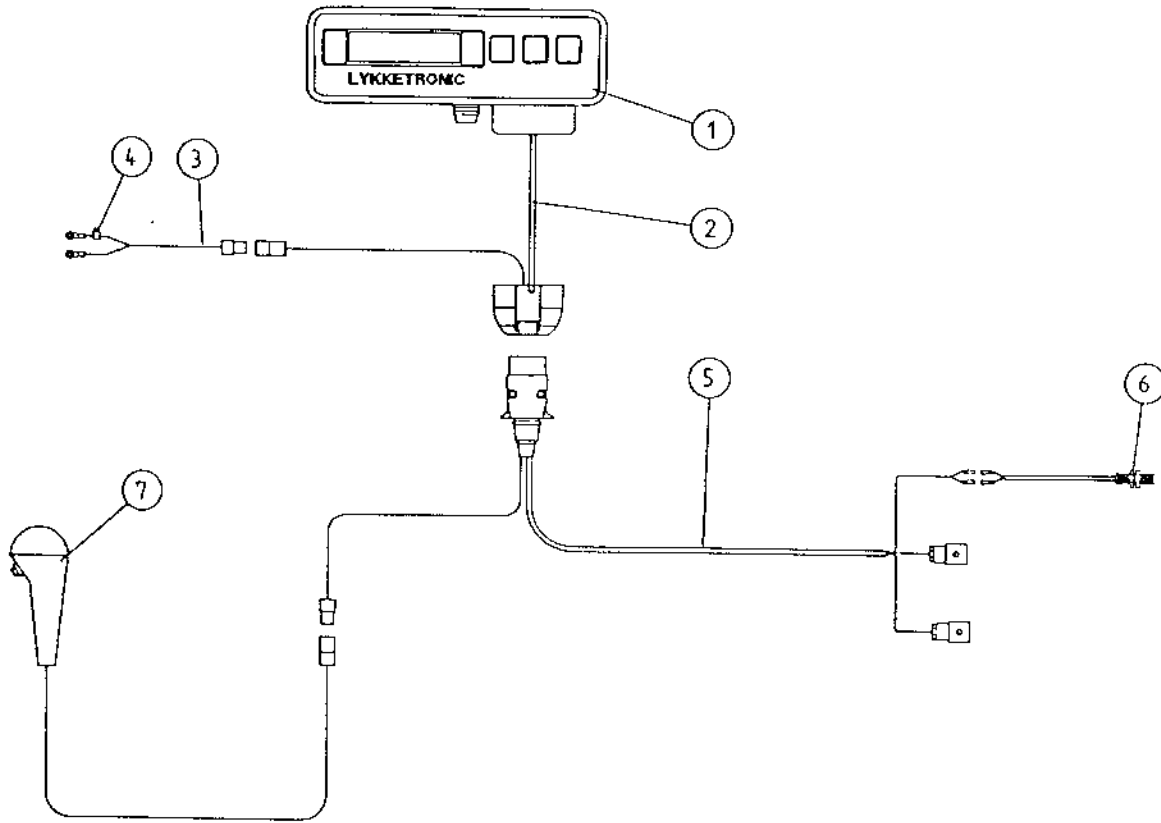

PARTS LIST

ITEM No.	DESCRIPTION	QTY.	PART No.
1	LYKKETRONIC PX MONITOR	1	D606C-S
2	7 PIN SOCKET CABLE 200mm LONG	1	ZLY-P08
3	MAIN BATTERY LEAD	1	ZLY-P12
4	7.5 AMP INLINE FUSE	1	ZD606-108
5	7 CORE CABLE C/W CONNECTORS	1	ZLY-P13
6	ROTATE SENSOR	1	ZLY-P14
7	JOYSTICK C/W MICROSWITCH	1	Z004-03-018

# Electrical circuit Diagram for Tanco 580S wrapper

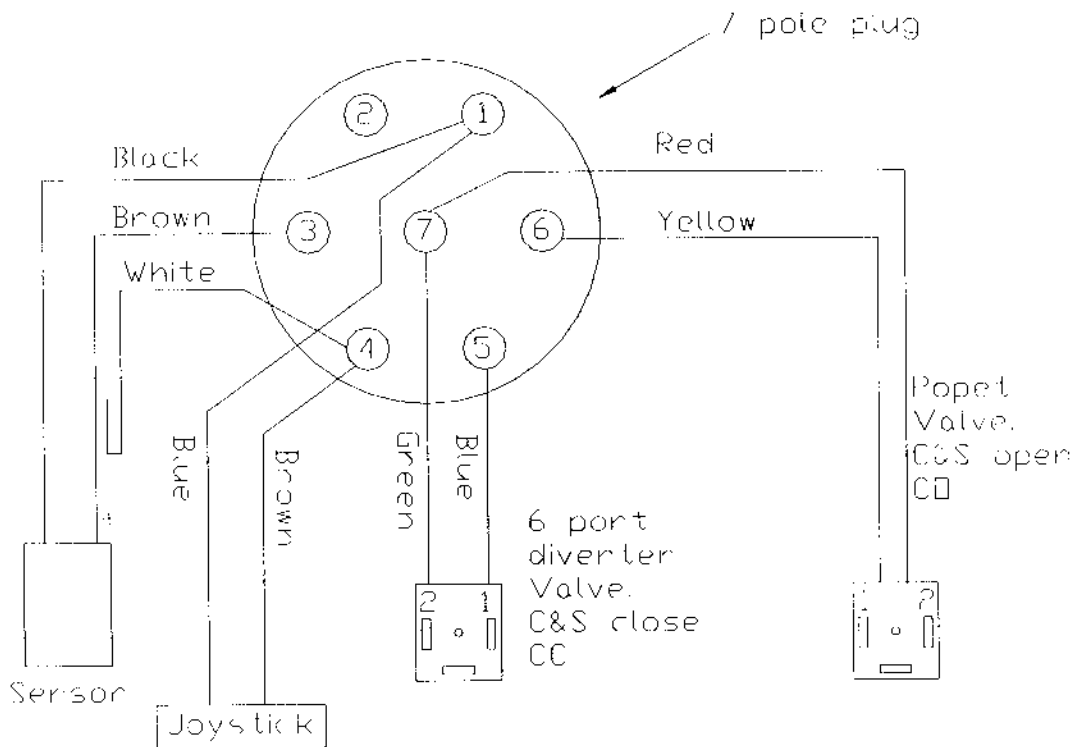
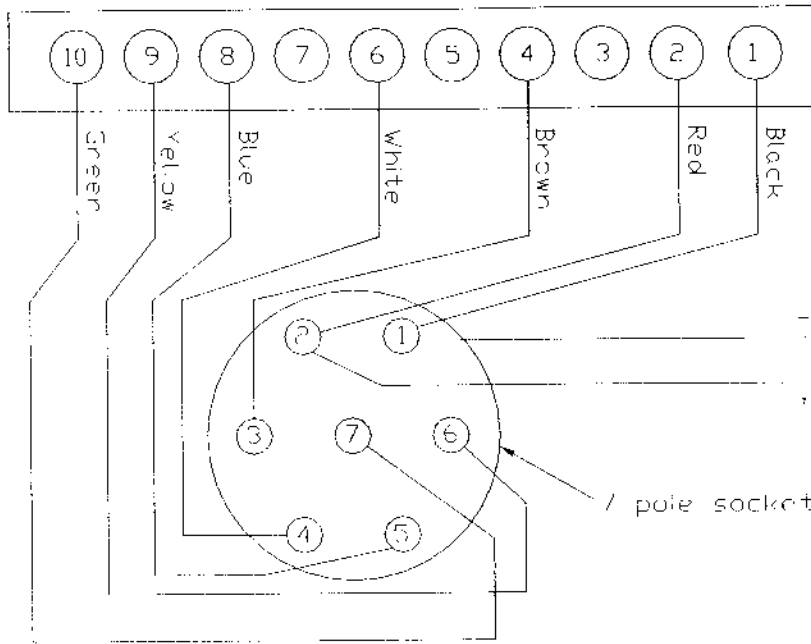

**TANCO AUTOWRAP CONSTANT INDEXING  
GEARBOX CHAIN DRIVE TENSIONING SYSTEM**

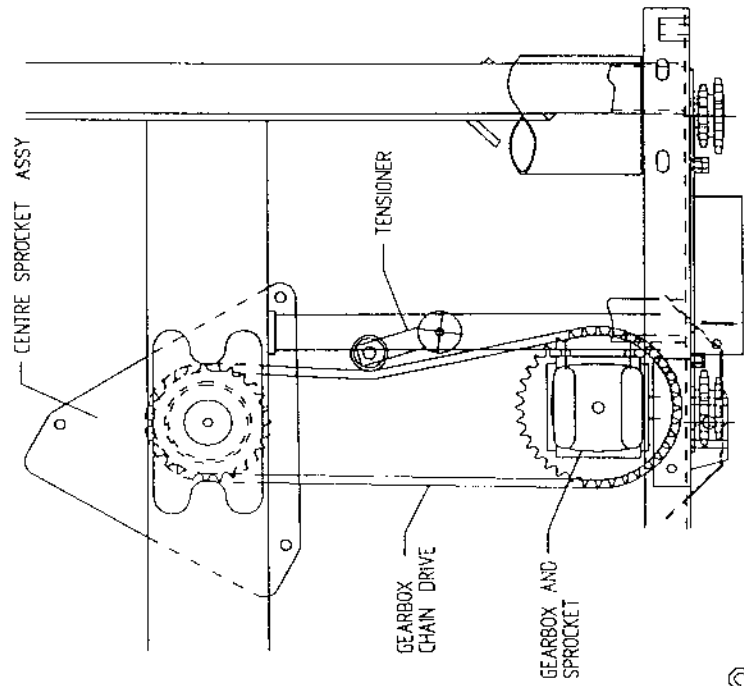

- CHAIN TENSIONING PROCEDURE**
1. LOOSEN M10 BOLT SECURING CHAIN TENSIONER.
  2. TENSION CHAIN BY ADJUSTING TENSIONER USING SPANNER IN DIRECTION OF ARROW "X" UNTIL SETTING OF 1.5-2.0 IS REACHED.
  3. RE-TIGHTEN M10 BOLT TO SECURE TENSIONER IN POSITION.

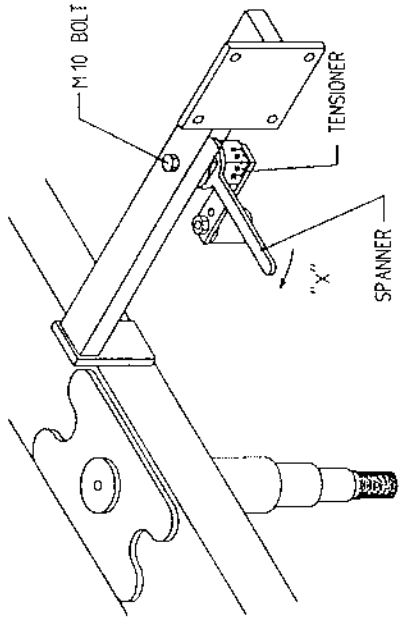

**Fig. 2**

**ROLLER CHAIN DRIVE TENSIONING SYSTEM**

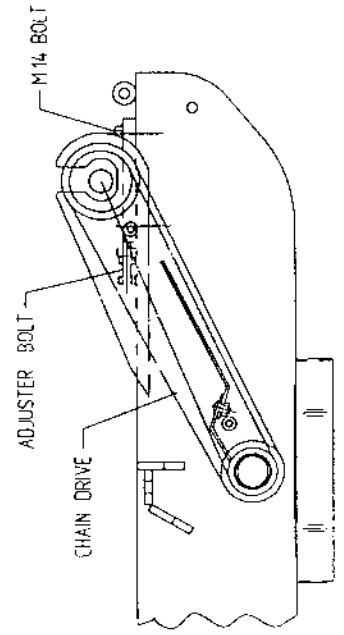

- CHAIN TENSIONING PROCEDURE**
1. LOOSEN M14 BOLTS SECURING BEARING.
  2. TENSION CHAIN BY LOOSENING LOCKING NUT AND TURNING ADJUSTER BOLT CLOCKWISE TO TAKE UP SLACK IN CHAIN. SECURE IN POSITION WITH LOCKING NUT. ENSURE EQUAL ADJUSTMENTS ARE MADE ON BOTH SIDES.
  3. RE-TIGHTEN M14 BOLTS SECURING BEARINGS TO 170Nm. (125 FT.LBS.).

**Fig. 3**

# TANCO AUTOWRAP TURNTABLE CHAIN DRIVE TENSIONING SYSTEM

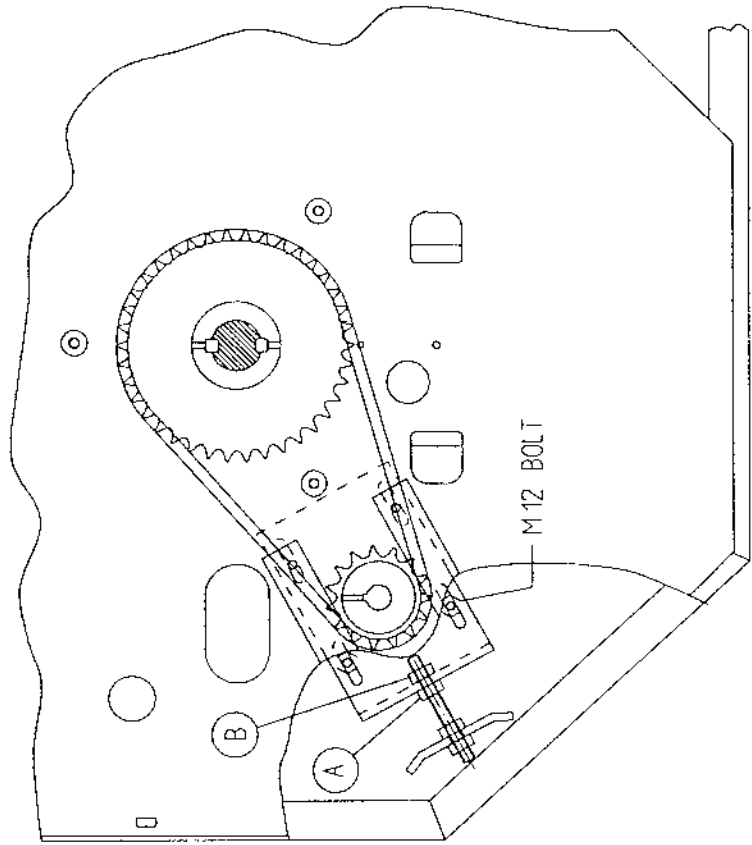

## TENSIONING PROCEDURE

1. TIP UP MACHINE AND SUPPORT WITH A PROP.
2. REMOVE CHAIN GUARD.
3. SLACKEN M12 CLAMPING BOLTS SLIGHTLY.
4. SLACKEN LOCKNUT A.
5. ADJUST NUT B UNTIL THERE IS 8 mm - 10 mm DEFLECTION ON CHAIN.

NOTE WARNING:  
DO NOT OVER TENSION CHAIN AS MOTOR WILL BE DAMAGED

6. TIGHTEN LOCKNUT A.
7. TIGHTEN M12 CLAMPING BOLTS.
8. REFIT CHAIN GUARD.

Fig. 8

# TANCO AUTOWRAP - HYDRAULIC CUT AND START

## INSTRUCTIONS FOR RECHARGING HYDRAULIC CYLINDER

1. REMOVE PLUG FROM PORT "A" .
2. CONNECT HOSE FROM HYD. HAND PUMP TO PORT "A" .
3. CHARGE CYLINDER TO A PRESSURE OF 60 BAR (870 P.S.I.)
4. REMOVE HOSE FROM PORT "A" AND REFIT PLUG .

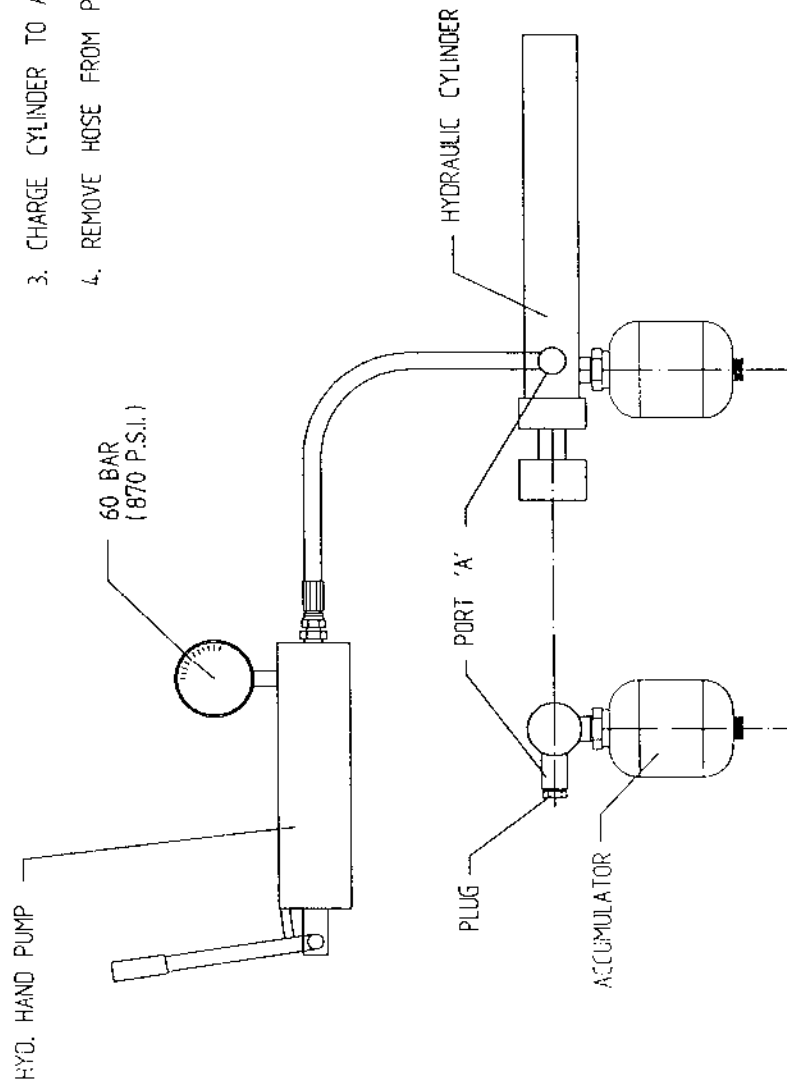

# FAULT FINDING

## PROBLEMS

## REMEDY

- |    |  |   |
|----|--|---|
| 1. | Drive Roller and Bale Belt not driving.                                      | Check and replace shear pins in sprocket on drive roller.   |
| 2. | Film not wrapping evenly on bale.  | Adjust film mast so centre of film roll is aligned with centre of bale.   |
| 3. | Tyres coming off 4" platform support wheels.                                 | Replace wheels – reduce speed below 25 r.p.m – do not grease path of wheels on platform. Check that bale does not get trapped between arms and turntable when being loaded.<br><br>If this happens lower arm and start again.   |
| 4. | Hydraulic Bale Ramp not returning to raised position after tipping off bale. | See instructions for recharging hydraulic cylinder.   |
| 5. | Bale Belt Tracking Adjustment:   |   |
|    | (i)  | Ensure vertical rollers (plastic) are in tight on the bale. Remember that the bale will reduce in size during wrapping and on the round bales in particular, the corners will become rounded so that the bale will tend to move sideways due to centrifugal forces. Now, if the plastic rollers are too far apart, the bale will move against one of the plastic rollers causing the belt to move in the opposite direction. Always adjust the vertical plastic rollers so that they keep the bale central on the belt. |
|    | (ii)   | Adjust bale stop on lift arm so that bale is loaded centrally onto platform.  |
|    | (iii)  | Check that bale belt is fitted so arrow points in direction of travel.  |
|    | (iv)   | Check that gripface strips are securely fixed to the roller and have not moved out of alignment.  |
|    | (v)  | See Bale Belt Tracking Instruction.   |