

**HYDRAULIC CUT AND START  
TANCO AUTOWRAP  
550-S MODEL 1997  
OPERATIONS HANDBOOK  
AND  
PARTS LIST  
WD 66- 550-S- 605H**

## GUARANTEE

Subject as hereunder provided, the Sellers undertake to correct either by repair or at their election by replacement any defect of material or workmanship which occurs in any of its goods within twelve months after delivery of such goods to first user, with the exception of contractors or commercial users when warranty period is six months.

In respect of Autowraps the warranty period is for 12 months or 8000 bales, whichever occurs first.

In respect of Aerways, tine breakage will be assessed on an individual basis in every case.

The term goods when used in this document means the article or articles described in Invoice as sold by the Sellers but does not include equipment or proprietary parts or accessories not manufactured by the Sellers. The Sellers, however, undertake to pass on so far as they legally can to the first user the benefit of any warranty given to the Sellers by the suppliers of such equipment, parts or accessories.

This understanding shall not apply to:-

- (a) Any goods which have been sold by the first user.
- (b) Any goods which have been injured by unfair wear and tear, neglect or improper use.
- (c) Any goods the identification marks of which have been altered or removed.
- (d) Any goods which have not received the basic normal maintenance such as tightening of bolts, nuts, tines, hose connections and fittings and normal lubrication with the recommended lubricant.
- (e) The use of any product on tractors exceeding the recommended horsepower.
- (f) Any goods which have been altered or repaired other than on instruction or with the written approval of the Seller or to which any part not manufactured or having written approval by the Sellers have been fixed.
- (g) Any second-hand goods or part thereof.

Any allegedly defective part or parts returned to the Sellers must be sent carriage paid. No claim for repair or replacement will be entertained unless upon discovery of the alleged defect written notification is sent to the Sellers giving, at the same time, the name of the Buyer from whom the goods were purchased and the date of purchase, together with full details of the alleged defect and the circumstances involved, also the serial number of the machine etc.

The Sellers shall be under no liability to their Buyers and first or subsequent users of their goods or to any other person or persons for loss or damages howsoever arising in respect of either personal injuries or for arising out of, or in any way connected with or arising from the manufacturers sale, handling, repair, maintenance, replacement or use of its goods or the failure or malfunction of any of its goods.

Representation and/or warranties made by any person (including Buyers and employees and other representatives of the Seller) which are inconsistent or conflicting with these conditions are not binding upon the Sellers unless given in writing and signed by a Director of the Sellers.

## CLAIMS.

If you wish to make a claim under guarantee:

- 1: Immediately, stop using the machine.
- 2: List the details of the machine, its serial number and the part number of the damaged part.
- 3: Consult with your Tanco dealer (supplier) and have him forward your claim and the damaged item to Tanco.

## **EXTENDED WARRANTY**

### **Applies only to Film Stretch Unit**

**SUBJECT TO THE FOLLOWING CONDITIONS:-**

- 1. UPON PURCHASE OF THE TANCO BALE WRAPPING MACHINE, PLEASE COMPLETE AND RETURN THE ATTACHED FORM.**
- 2. THE SERIAL NUMBER IS ON THE CENTRE ROD OF THE K.O. PRE-STRETCH FILM DISPENSER.**
- 3. RETURN THE SLIP DIRECT TO K.O. PRESSURE FRAMES OR TANCO ENGINEERING WITHIN ONE MONTH OF PURCHASE.**

**UPON RECEIPT, K.O. PRESSURE FRAMES LIMITED WILL WARRANTY THE FILM TENSIONING UNIT FOR 2 YEARS FROM DATE OF PURCHASE SUBJECT TO THE TERMS AND CONDITIONS OF THE TANCO MACHINE WARRANTY AND SUBJECT TO THE CORRECT LUBRICATION OF THE FILM DISPENSERS GEARBOX, WHEREBY ONE SHOT OF GREASE EVERY 500 BALES. USE ONLY NLGI 0 GRADE LITHIUM GREASE, WE RECOMMEND SILKOLENE G46 SL EP GREASE OR APPROVED EQUIVALENT, i.e. ESSO BEACON EPO.**

**WARRANTY RETURN FORM**

**PURCHASERS NAME:**.....

**ADDRESS:** .....

.....

**POST CODE:** ..... **COUNTRY:**.....

**TELEPHONE NO:** ..... **FAX NO:**.....

**K.O.P.F. DISPENSER SERIAL NUMBER(S):** .....

**TANCO AUTOWRAP SERIAL NUMBER(S):**.....

**DATE OF PURCHASE:**.....

*PLEASE RETURN TO: K.O. PRESSURE FRAMES LTD, UNIT 3, CHIDDINGSTONE  
CAUSEWAY ESTATE, NR. PENSHURST, KENT. TN11 8JU  
ENGLAND*

**OR** *TANCO ENGINEERING CO. BAGENALSTOWN, CO. CARLOW,  
EIRE*

GENERAL SAFETY INSTRUCTIONS .....	1/2/3
SAFETY INSTRUCTIONS .....	4
SAFETY DECALS .....	5
TECHNICAL SPECIFICATIONS .....	6
PRE-DELIVERY INSTRUCTIONS.....	7/8/9
TRANSPORT INSTRUCTIONS.....	10
MACHINE IDENTIFICATION .....	10
PREPARATION OF A NEW MACHINE .....	10
HYDRAULIC CONNECTIONS .....	10
BALE WRAP CONTROLLER 450S/550S MODEL .....	11
BALE WRAP CONTROLLER FUNCTIONS .....	12
JUNCTION BOX & CONTROLLER FOR 3 BANK VALVE .....	13
AUTOMATIC BALE WRAP CONTROLLER 550A MODEL .....	14
OPERATOR ACCESSABLE MONITOR PROGRAMMES 550A MODEL .....	15/16/17
MODE OF OPERATION 550A MODEL .....	18
OPERATING INSTRUCTIONS .....	19
WARNING: LIFT ARM .....	19
FILM OVERLAP SYSTEM .....	20
SERVICE AND MAINTENANCE .....	21/22
FILM THREADING DIAGRAM .....	23
GEARBOX CHAIN DRIVE TENSIONING SYSTEM .....	24
TURNTABLE CHAIN DRIVE TENSIONING SYSTEM .....	25
FILM ADAPTOR OPERATING INSTRUCTIONS.....	26
ELECTRICAL COMPONENTS 450S/550S MODEL .....	27
ELECTRICAL COMPONENTS 550A MODEL .....	28
HYDRAULIC CIRCUIT DIAGRAM 450S/550S MODEL .....	29
HYDRAULIC CIRCUIT DIAGRAM 550A MODEL .....	30
HYDRAULIC COMPONENTS 450S/550S MODEL .....	31
PARTS LIST FOR ABOVE .....	32
HYDRAULIC COMPONENTS 550A MODEL .....	33
PARTS LIST FOR ABOVE .....	34
FITTING 2 WAY SOLENOID VALVE .....	35
CONSTANT INDEXING DRIVE ASSEMBLY .....	36
PARTS LIST FOR ABOVE .....	37
AUTOWRAP ILLUSTRATED .....	38
PARTS LIST FOR ABOVE .....	39
TURNTABLE CHAIN DRIVE ASSEMBLY .....	40
LIFT ARM ASSEMBLY .....	41
FILM DISPENSING SYSTEM 550S/550A MODEL .....	42
PARTS LIST FOR ABOVE .....	43
VALVE/JUNCTION BOX/FILTER & DIVERTER VALVE MOUNTING BRACKET ASSEMBLY .....	44
FAULT FINDING SUMMARY .....	45
CUT AND START UNIT ILLUSTRATED .....	46
PARTS LIST FOR ABOVE .....	47
SLIP RING ASSEMBLY .....	48
SENSOR MAGNET MOUNTING BRACKETS .....	49
HYDRAULIC BALE RAMP .....	50
PARTS LIST FOR ABOVE .....	51
LIGHTING KIT .....	52
CUT AND START FAULT FINDING SUMMARY .....	53/54/55/56

Fig 1	-	Page no. 23
Fig 2	-	Page no. 24
Fig 3	-	Page no. 24
Fig 5	-	Page no. 22
Fig 6	-	Page no. 11
Fig 7	-	Page no. 14
Fig 8	-	Page no. 25

## GENERAL SAFETY RECOMMENDATIONS

Before operating the machine, always ensure that the tractor and machine meet with work safety and road traffic regulations.

### BASIC PRINCIPLES

- 1: In addition to the recommendations given in this manual, legislation on work safety and accident prevention must also be respected.
- 2: Advice is indicated on the machine, specifying safety recommendations in order to prevent accidents.
- 3: Before travelling on public roads, the operator must ensure that the machine conforms to road traffic regulations.
- 4: Before starting work, the operator must be familiar with all machine controls, handling devices and their functions. Once at work, it is too late to do this!
- 5: Do not wear loose clothing which could become caught up in moving elements.
- 6: The tractor should be equipped with a safety cab.
- 7: Before starting up the machine and beginning work, check the surrounding area (beware of children!). Make sure there is sufficient visibility. Keep all people and animals away from the danger zone of the machine (risk of projection!).
- 8: Carrying people or animals on the machine when working or in transport is strictly forbidden.
- 9: Machine must only be attached to tractor using means provided and in accordance with current safety standards.
- 10: Special care should be taken when attaching or removing the machine from the tractor.
- 11: Before transporting the machine on public roads, ensure that all legally required guards and indicators (lights, reflectors ...) are in place and in good operation.
- 12: All operating controls (cords, cables, rods etc.) must be positioned so that they cannot be set off accidentally, risking accident or damage.
- 13: Before travelling on public roads, put the machine into its transport position as instructed in this operators manual.
- 14: Never leave the tractor seat while the machine is operating.
- 15: Drive speed must be adapted to ground conditions as well as to roads and paths. Always avoid abrupt changes of direction.
- 16: Before operating the machine, ensure that all safety guards are firmly in place and in good condition. If worn or damaged, replace immediately.
- 17: Before operating the machine, check the tightness of all nuts and bolts, particularly on fixing elements (blades, tines, knives, spades etc.,).
- 18: Keep clear of the machine operating area.
- 19: **WARNING!** Danger of crushing and shearing can exist when components are operated by hydraulic or pneumatic controls.
- 20: Before leaving the tractor or before adjusting, maintaining or repairing the machine, turn off the engine, remove the ignition key and wait until all moving parts have come to a complete stop.

- 21: Do not stand between the tractor and the machine unless the hand brake is tight and/or stops have been placed under the wheels.
- 22: Before any adjustments, maintenance or repairs are carried out, ensure that the machine cannot be started up accidentally.

#### **ADDITIONAL RECOMMENDATIONS FOR LINKAGE MOUNTED MACHINES**

- 1: Before attaching the machine, ensure that the front tractor axle is sufficiently ballasted. Ballast is to be placed on the supports provided in accordance with instructions of the tractor manufacturer.
- 2: Do not exceed the maximum axle load or the overall transport weight prescribed by the tractor manufacturer.
- 3: Precision steering, tractor adherence, road holding and efficient braking are influenced by the type of implement, weight, ballast of front axle, ground or road conditions. It is therefore of utmost importance to be cautious in every given situation.
- 4: Be particularly cautious when turning corners, paying attention to machine overhang, length, height and weight.

#### **SAFETY RECOMMENDATIONS FOR ATTACHING IMPLEMENTS TO TRACTOR**

- 1: When attaching or removing the machine from the tractor, position hydraulic lift control lever in such a way that it cannot be set off accidentally.
- 2: When attaching the machine to the tractor hydraulic linkage, ensure that diameter of the link pins corresponds to the diameter of the ball joints.
- 3: **WARNING!** Danger of crushing and shearing can exist in the lifting zone of the tractor hydraulic linkage!
- 4: Do not stand between the tractor and the machine when operating the outer lever of the lift mechanism.
- 5: In transport, the machine lift mechanism should be stabilized by tractor tie rods to avoid floatation and side shifting.
- 6: When transporting the machine, lock the hydraulic lift control lever in place so that it cannot be lowered accidentally.

## HYDRAULIC SYSTEM

- 1: **WARNING!** Hydraulic system is under pressure.
- 2: When fitting hydraulic motors or cylinders, ensure that connections have been made correctly, as per manufacturers instructions.
- 3: Before connecting hoses to the tractor hydraulics, ensure that tractor and machine circuits are not under pressure.
- 4: It is strongly recommended that the operator marks the hydraulic connections between tractor and machine to avoid making a wrong connection.  
**WARNING!** Functions could be reversed (for example: lift/lower).
- 5: Check hydraulic hoses regularly! Worn or damaged hoses must be replaced immediately. Replacement parts must be in accordance with the manufacturers recommendations concerning specifications and quality.
- 6: Should a leak be found, take all necessary precautions to avoid accidents.
- 7: Any liquid under pressure (particularly oil from hydraulics) can penetrate the skin and cause severe injury. If injured, see a doctor immediately, there could be a danger of infection.
- 8: Before any adjustments, maintenance or repairs are carried out, lower the machine, depressurize the circuit, turn off the engine and remove the ignition key.

## MAINTENANCE

- 1: Before checking for any machine malfunction and before adjusting, maintaining or repairing the machine, turn off engine and remove ignition key.
- 2: Check tightness of nuts and bolts regularly. Retighten if necessary.
- 3: If the machine is raised, prop it up in a stable position before carrying out any maintenance work.
- 4: When replacing a working part, wear protection gloves and use only standardized tools.
- 5: It is forbidden to discard any oil, grease or filters. These must be given to waste disposal organisations to protect the environment.
- 6: Disconnect power source before any work is done to the electric system.
- 7: Check safety guards regularly, particularly those that are subject to wear. Replace immediately if damaged.
- 8: Spare parts used must be in accordance with specifications and standards as defined by the manufacturer. Use only genuine TANCO parts.
- 9: Before any electric welding is carried out on tractor or attached machine, disconnect generator and battery terminals.
- 10: Repairs on elements under pressure or tension (springs, accumulators etc.) must only be carried out by competent persons with standardized equipment.



#### SPECIAL SAFETY INSTRUCTIONS

1. Stop engine of tractor before working on machine.
2. Put a suitable prop under raised platform before working in this area.
3. Always raise Lift Arm and fit safety prop before transporting machine on public roads.
4. Lift Arms should always be lowered before operating turntable.
5. Ensure platform rollers are parallel to Lift Arm before arm is raised.
6. On Autowrap models fitted with hydraulic bale ramp it is essential that the hydraulic hose is not disconnected from the hydraulic cylinder or hydraulic accumulator. This system is charged under pressure. Also, do not attempt to open the hydraulic accumulator as this is a pressurised unit.

#### OPERATING SAFETY INSTRUCTIONS

1. Operators should have their hands on the controls at all times when machine is in use.
2. Autowrap control unit and level controls must remain in the tractor cab at all times. The operator must at no time leave the tractor cab when the machine is in motion.
3. Keep onlookers clear of machine at all times. Danger zone is 5 metres.
4. Beware of rotating turntable and all moving parts.
5. If not operated correctly the bale could fly off the turntable. The end support rollers must always be fitted. Do not exceed recommended turntable speed of 30 r.p.m. Mis-shapen bales combined with excessive turntable speeds can be dangerous.
6. Care must be taken when tipping bales from machine on sloping ground and during subsequent handling to ensure that they do not roll, thus causing hazard.

THINK OF YOUR PERSONAL SAFETY AND THAT OF OTHERS AT ALL TIMES.

# SAFETY DECALS

The following safety decals have been placed on your machine in the areas indicated. They are intended for your personal safety and for the safety of the people working with you. With this manual, walk around your machine and note the content and location of these warning signs. Review these decals and the operating instructions in the manual with your machine operators. Ensure that these decals are always legible. If they are not, replace them.

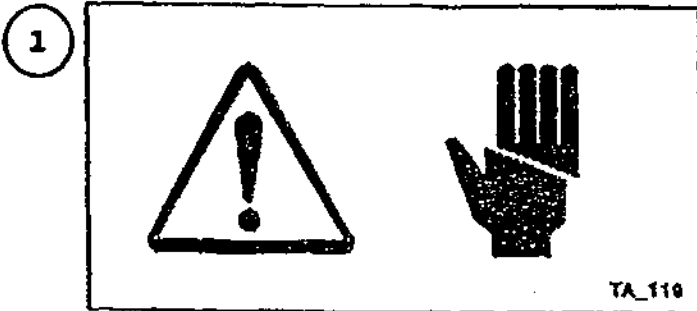
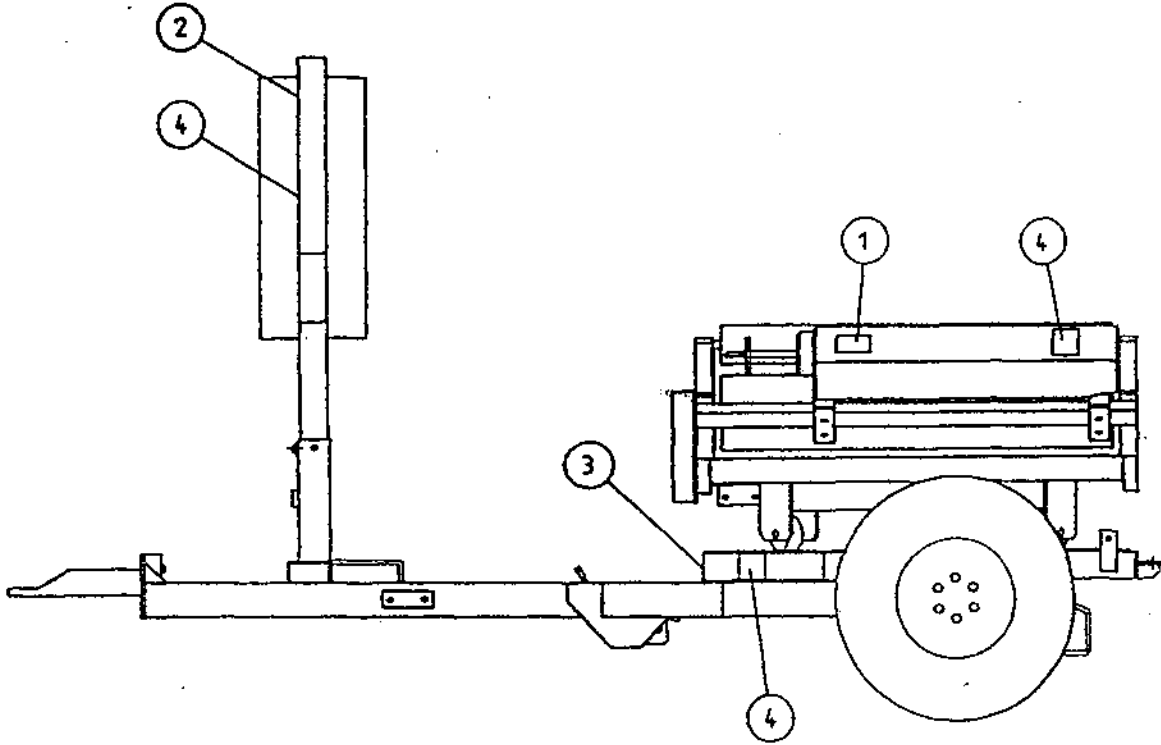

**WARNING SHARP KNIFE**



**BEFORE STARTING THE MACHINE READ OPERATORS MANUAL AND SAFETY INSTRUCTIONS**

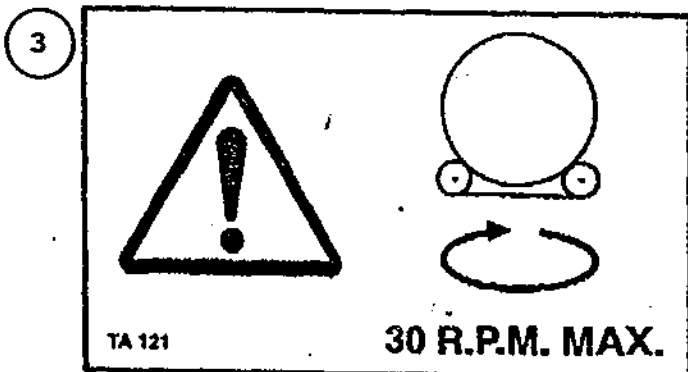

**DO NOT EXCEED TURNTABLE SPEED OF 30 R.P.M**

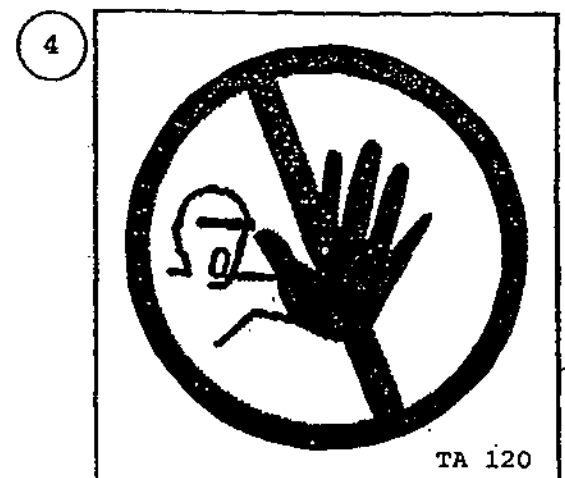

**DANGER STAND CLEAR**

## TECHNICAL SPECIFICATIONS

550S/550A  
Models Trailed

### Dimensions

Total length - Excluding Bale Ramp	...	...	350cm
Width - excluding lift arm	...	...	221cm
" - lift arm fully raised	...	...	243cm
" - lift arm lowered	...	...	380cm
Height to top of side (bale guide) rollers			110cm
Height to top of lift arm	...	...	242cm

### Weight

With lift arm	...	...	1080kgs
Without lift arm	...	...	960kgs

### Wheels

Size	...	...	10-80. 12
Pressure	...	...	42 p.s.i.

Lift arm capacity - Axle extended normally	...	...	750kgs
" " " - Axle extended fully	...	...	1000kgs

Speed of turntable	...	...	30 rev/min*
Oil requirement	...	...	(165 kpcm <sup>2</sup> ) 25 lit/min

Attachment to tractor	...	...	Tractor Hitch
-----------------------	-----	-----	---------------

Bale Sizes	...	...	120 x 120cm up to 150 x 150 cm max weight of 1000kgs
------------	-----	-----	--

Film (Width of Roll)	...	...	500mm on 450S 750mm on 550S " " 550A
----------------------	-----	-----	--

\* The speed of rotation can be varied to suit various conditions but on no account should it exceed 30 r.p.m. (Speed in excess of 30 r.p.m. will void warranty).

## PRE DELIVERY INSTRUCTIONS

**IMPORTANT: DO NOT ATTEMPT TO OPERATE UNTIL THE FOLLOWING INSTRUCTIONS ARE PERFORMED OTHERWISE SERIOUS DAMAGE COULD BE CAUSED.**

### 1. MACHINE ASSEMBLY

For ease of transportation some items are removed from their positions and stored elsewhere on the machine. The control box, film dispenser and cut and start unit are stored under the bale belt. Also stored under belt on remote control machines are the infra red receiver and sender units and warning beacon. The film mast is attached to the front of the machine. On round bale machines only, the top rollers c/w mounting brackets and the plastic end rollers are mounted on temporary brackets beside the bale belt. Road wheels, bale lift arm and bale ramp are transported separately. Remove the above items and assemble as detailed in parts list section of this manual taking particular note of the following points.

#### (i) DISPENSER MAST

Insert lift mast into socket towards front of machine. Ensure film pull down ram is faced towards the machine. Attach the pull down arm hydraulic ram. Attach the film dispenser to the mast ensuring that the end marked top is faced up. On remote control machines attach the infra-red receiver and warning beacon to top of mast. The film mast is adjustable. Its position is dependant on bale size and type and is set in the field. It should be set so that centre line of film is in line with centre of bale. See Fig. 1

#### CUT & START

Attach Cut & Start unit to mounting frame on the left hand side of the machine. It is possible to move the unit along the mounting and fix it.

#### (iii) BALE LIFT ARM

Assemble bale lift arm and attach to mounting points on right hand side of main chassis. Attach hydraulic ram to lift arm; grease pivot pins.

#### (iv) TOP ROLLERS AND PLASTIC END ROLLERS

Place plastic end rollers in sockets on the back and front of the turntable. On round bale machines only, attach top rollers and mounting brackets to each side of the machine.

(v) ROAD WHEELS (trailed machines only)

Attach road wheels ensuring that nuts are tight and tyre pressure is 50 p.s.i.

(vi) BALE RAMP OR MAT

Attach bale ramp or mat to rear of chassis. Note Round bale trailed models have bale ramps with an option of hydraulic bale ramp.

Linkage mounted machines have bale mats. The standard 1050 trailed models have hydraulic bale ramps.

SEE INSTRUCTION BELOW FOR FITTING HYDRAULIC BALE RAMP.

CHECKS TO BE PERFORMED

1. Check that all bolts and nuts are tight.
2. That all lubrication points are greased.
3. Check that all guards are in place.
4. Check all operating and safety stickers are in place.

INSTRUCTIONS FOR FITTING HYDRAULIC BALE RAMP

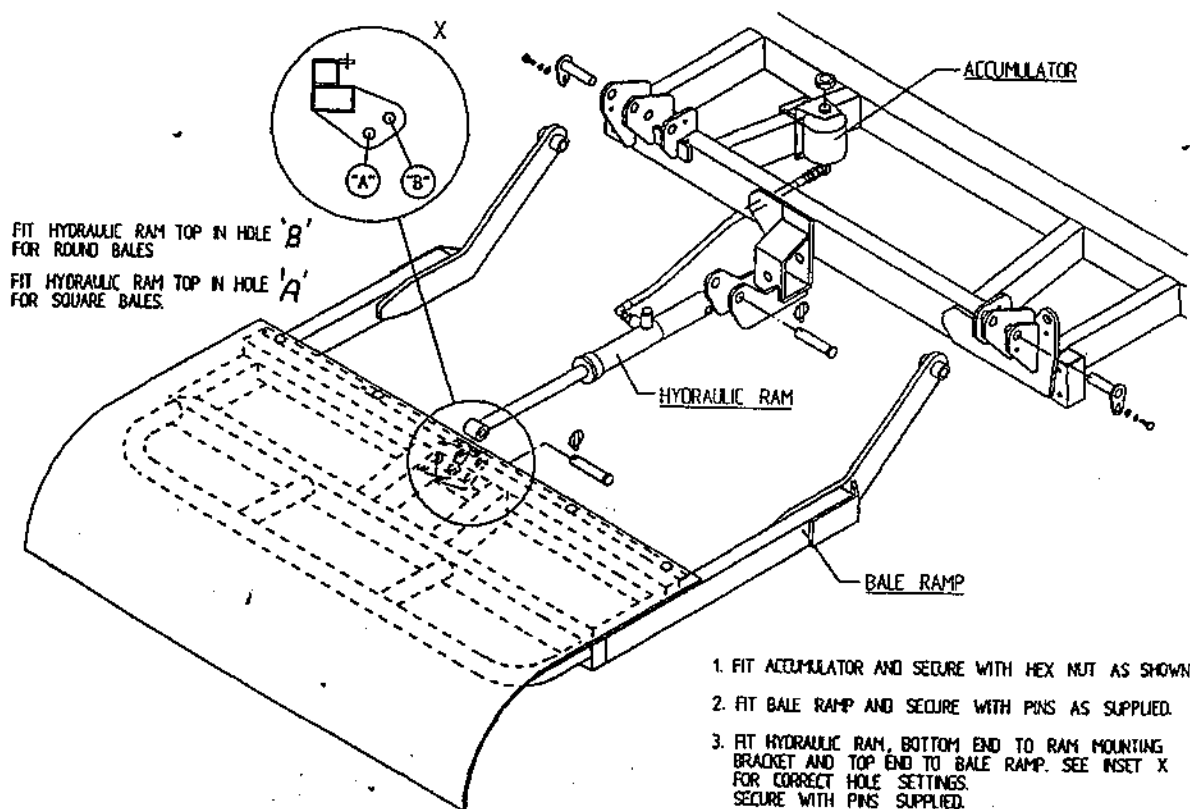

## **2. OPERATIONAL TEST**

When all above assembly and checks have carried out the operation of the machine should be checked as follows.

Note: If you are not totally familiar with the operation of the tanco control system read this manual in full before proceeding with operational test.

1. Attach machine to tractor.
2. Connect hydraulic hoses to D/A service on tractor.
3. Fit bale wrap controller inside cab.
4. Connect Bale Wrap controller to machine and connect power cable direct to tractor battery. It is important that the leads are connected with the correct polarity.
5. Fit cable control actuator socket to convenient position in cab and locate actuators in socket .
6. Lock hydraulic lever in tractor so that oil is flowing through system.
7. Check function by operating control levers.
  - a) Lift arm up and down
  - b) Turntable rotation forward
  - c) Tip up and down checking hoses are ok
10. Check Cut and Start plunger out and in.
11. See operating instruction section of this manual on how the machine should perform, and if any function fails to operate correctly consult fault finding section of the operators manual.

## **3. CUSTOMER CHECKS**

Before the machine model suits his requirements, :

1. That the machine model suits his requirements.
2. If machine is to be operated on a tractor with a closed centre hydraulic system then a closed centre valve is required , see separate instructions.
3. That the tow hitch type is compatible with the tractor. Three different hitch types are available.

## TRANSPORT INSTRUCTIONS

1. Never use straps around the machine when lifting. Use only the following lifting points:- Tow hitch and two sockets on each side of main frame at rear for trailed models. 3pt. Linkage frame and two sockets on each side of main frame at rear for 3 pt. Linkage Model.
2. When the machine is towed on the road the Lifting Arm (if fitted) must be in the fully raised position, the safety prop fitted and the axle returned to narrowest position.
3. Raise the Parking Jack on trailed models before moving machine.

## MACHINE IDENTIFICATION

The Serial Number plate is located on main frame forward of offside wheel on trailed models and on 3pt. Linkage frame for 3pt. Linkage model.

Always refer to this number when ordering parts.  
The Spare parts catalogue number and description should be used. The reference numbers are used to help identifying the spare part.

For your records write serial number here.

SERIAL NO. \_\_\_\_\_

## PREPARATION OF A NEW MACHINE

1. Check height of film mast to ensure that centre line of film spool is level with the centre line of the bale on the turntable. This will alter with different bale diameters. If this alignment is not correct more film than necessary will be used. See fig 1.
2. When connected to John Deere\* tractor the value must be converted to closed centre.

## HYDRAULIC CONNECTIONS

Connect the feed and return hoses from the Autowrap valve to the tractors double acting facility.

NOTE: The return hose is fitted with a non-return valve to protect the Autowrap from damage in the event of incorrect connection to tractor hydraulics.

NOTE: To ensure maximum efficiency and length of lift of hydraulic components this machine requires a clean supply of hydraulic oil. IT IS RECOMMENDED THAT THE TRACTOR HYDRAULIC FILTER ELEMENT TO BE REPLACED AND THEREAFTER MAINTAINED IN ACCORDANCE WITH THE MANUFACTURERS RECOMMENDATIONS.

## BALE WRAP CONTROLLER

Connect direct to battery as per operating instructions. The programming of the Bale Wrap Controller is easily done by following the steps outlined below.

Once the unit is switched on the number of required turntable revolutions appears on the right hand display. To change this press and hold the "hold to set" button, see fig 6, then press the "set/reset" button. The first digit of the number will then blink and count from 0-9. Release the "set/reset" button at the required number. By pressing the "set reset" again the second digit can be changed.

The monitor counts the number of bales per batch and the cumulative total. To see these, press the "bale count" button. The first number to appear is the batch total. If the button is held down for 10 seconds a line will appear on the display, followed by the cumulative number wrapped. The batch count can be reset to 0 by holding the "bale count" button down and pressing the "set/reset" once. The cumulative total cannot be returned to zero.

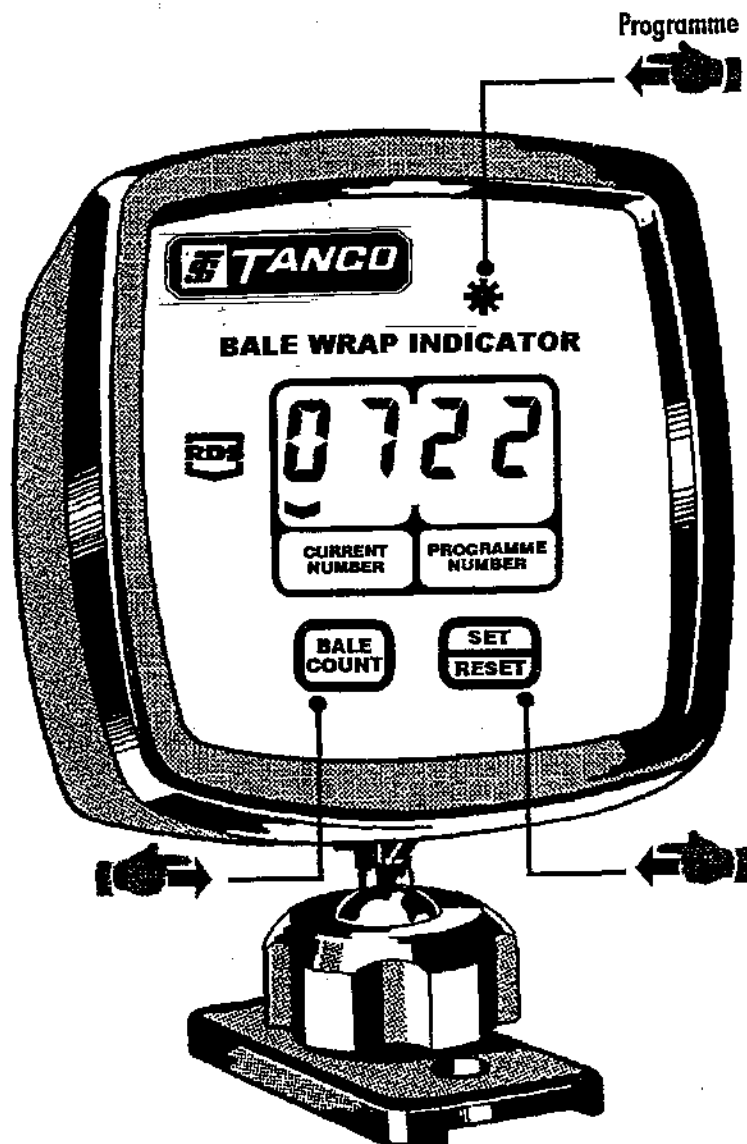



## **BALE WRAP CONTROLLER FUNCTIONS**

### **The Bale Wrap Controller Functions**

The Bale Wrap Controller has a total of three functions to control.

To access these functions press/hold \* button and re connect power then release \* button.

A Chevron V appears at the left hand side of the display windows:- this may be moved across the display from left to right by repeatedly pressing button \* .

The three chevron positions have specific functions and the time for each function may be set by the two buttons at the bottom of the display screen.

- < > +

Reading from left to right the chevron positions are as follows:

1. Indicates number of turntable revolutions before cut and start opens. = 2
2. Indicates the number of revolutions of the turntable when solenoid valve switches off = 3
3. Indicates the number of revolutions before the set figure at which the buzzer sounds = 0.

Finally to lock all functions into the controllers memory, switch power off and back on again.

## **OPERATING INSTRUCTIONS**

1. Fit roll of film and thread through the dispenser roller assembly by following the instruction label on the film mast.
2. Set the bale wrap indicator to the correct setting for the size of the bale being wrapped and the width of film being used. See Table 1 for list of some recommended setting.
3. Power down lift Arm until wheel is clear of ground and adjust wheel outward to appropriate setting for bale weight.
4. Adjust tractor engine speed to give turntable speed of 16-30 r.p.m. will void warranty.
5. Position turntable with cut and start unit facing front of machine.
6. Attach film tag end to gripper section of cut and start unit.
7. Rotate turntable anticlockwise through 90 degrees and stop turntable with cut and start unit opposite to lift arm.
8. Locate bale on lift arm, then raise lift arm and gently roll bale onto turntable. Lower arm.
9. Start wrapping , turntable rotating clockwise. Film tension is automatically set so that width of film applied to the bale stays at approx width of 400mm for 500mm wide film roll and 600mm for 750mm wide film roll.
10. Continue wrapping until signal from bale wrap indicator sounds (requires number of revolutions has been reached). Then stop with cut and start unit facing towards front of machine and film aligned with gripper section of cut and start unit.
11. Tip up machine. When the film is fully gathered on the cut and start, press and hold micro switch on Joystick to close cut and start, which grips and cuts film. Release micro switch and bale is tipped off.
12. lower the turntable and rotate anticlockwise through 90 degrees and stop with cut and start unit opposite to lift arm.
13. Repeat operations 7-12 as required.

**NOTE: The film end need only be attached at the start of a roll, after that the sequence is automatic.**

### **WARNING LIFT ARM**

The Lift Arm on the trailed machine is designed to pick up and deposit bales onto the turntable prior to wrapping and to raise the machine while empty, to facilitate adjustment to sliding axle. It is not intended to be used for transporting bales over distances or for use as a stabiliser whilst wrapping.

## FILM OVERLAP SYSTEM.

The Autowrap is fitted as standard with the 2 x 2 x 50% film overlap system. This is achieved by means of a chain drive which ensures that the correct number of film layers are applied to the bale after a specific number of revolutions of the turntable. The number of revolutions required to wrap a bale depends on width of film being used and bale size - See Table 1 below. The chain to be positioned on inner sprockets for 750mm wide film and on outer sprockets for 500mm wide film. See fig. A below.

For silage bales we recommend the application of a minimum of four layers of film.

Table 1

Bale Size	Width of Film Roll	Bale Indicator Setting (Revs)
120cm x 120cm	500mm	25
120cm x 120cm	750mm	17
120CM x 137cm	500mm	28
120CM x 137cm	750mm	19
120CM x 150cm	500mm	31
120CM x 150cm	750mm	21

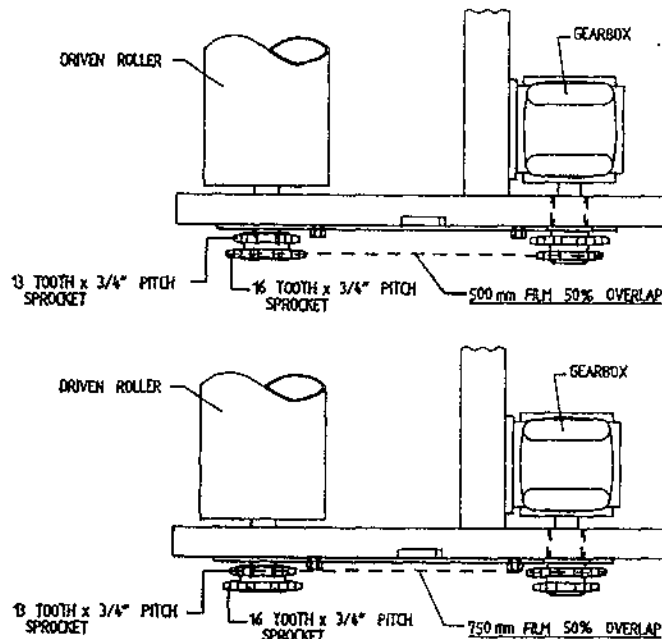

FIG. A

### IMPORTANT

The above recommendations are only offered as a guide to correct wrapping of silage bales and the manufacturer accepts no responsibility for variations that may arise and the consequence of same. They are based upon turntable speeds of up to 25 r.p.m., and a approx film width of 400mm applied to end of Bale when using 500mm wide film roll or a approx film width of 600mm applied to end bale when using 750mm wide film roll.

It is the responsibility of the operator to ensure the correct number of wraps are applied, as variances can occur with fluctuations in speed of rotation, film quality and tensioning, shape and density of bale etc.

## SERVICE AND MAINTENANCE.

- 1: All nuts and bolts should be tightened after one hour in use and thereafter regularly.
- 2: Wheel pressure should be normally kept at 42 psi depending on bale weight and field conditions.
- 3: Inspect moving parts for wear on daily basis.

4: Lubrication.

Drive chain & sprocket	-	Grease every 24 hours.
Main rollers	-	Grease every 24 hours.
Hinge pins on Lift Arm	-	Grease every 24 hours.
Hinge pins on main tip frame	-	Grease every 24 hours
Hydraulic rams	-	Grease every 24 hours.
Film spool assy.	-	Grease every 24 hours.
Dispenser gearboxes	-	One shot of Grease every 500 bales. See 6.
Main spindle	-	Grease every 4000-5000 bales.

5: Adjustments.

Turntable Drive chain.	Adjust after first days work then check/adjust every 50 hours. See Fig. 8.
Gearbox Drive chain:	Adjust after first days work then check/adjust every 50 hours. See Fig. 2.
Roller Drive chain:	Adjust after first days work then check/adjust every 50 hours. See Fig. 3.
Main Bale Belt:	See belt tracking instructions.

6: Film Dispenser.

Fit with marked gearbox at top.

Apply one shot of grease every 500 bales .Use only **NLGI O GRADE LITHIUM GREASE**. We recommend **SILKOLENE G46 SL EP** grease or approved equivalent, i.e. **ESSO BEACON EPO**. Wash rollers often to avoid build up of Tack from film using petrol. Follow film threading diagram. See Fig. 1.

7: Film Adjustment.

Centre of film roll must be in line with centre of bale and film mast should be vertical.

8. Shear Pins

There are two shear pins fitted to sprocket assembly on drive roller see fig 5. If the pins shear, remove the broken pins re-align holes and fit two replacement spiral pins, 6mm dia x 20mm long, Din 7344. There are two spare shear pins attached to inside of chain guard.

NOTE: If shear pins are replaced with other than specified above all warranty is null and void.

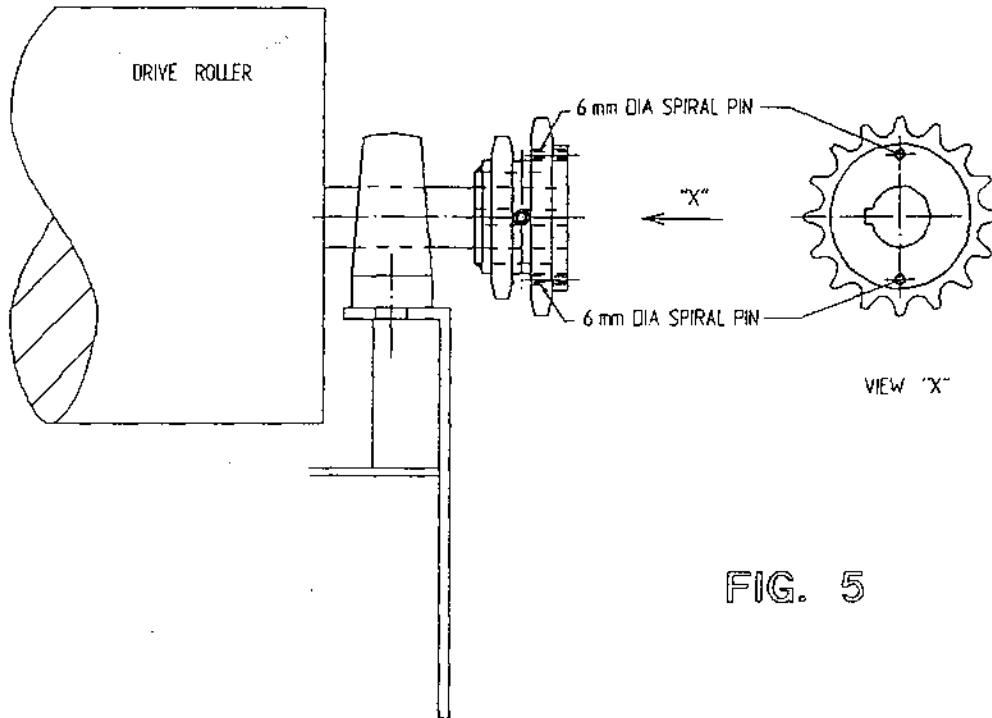
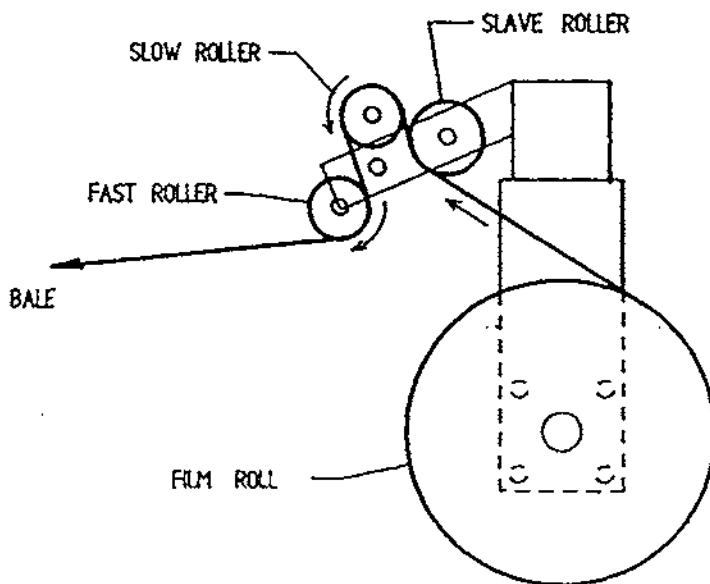

FIG. 5

# TANCO AUTOWRAP FILM THREADING DIAGRAM



## FILM ADJUSTMENT

CENTRE OF FILM ROLL MUST BE IN LINE WITH CENTRE OF BALE AND FILM MAST SHOULD BE VERTICAL.

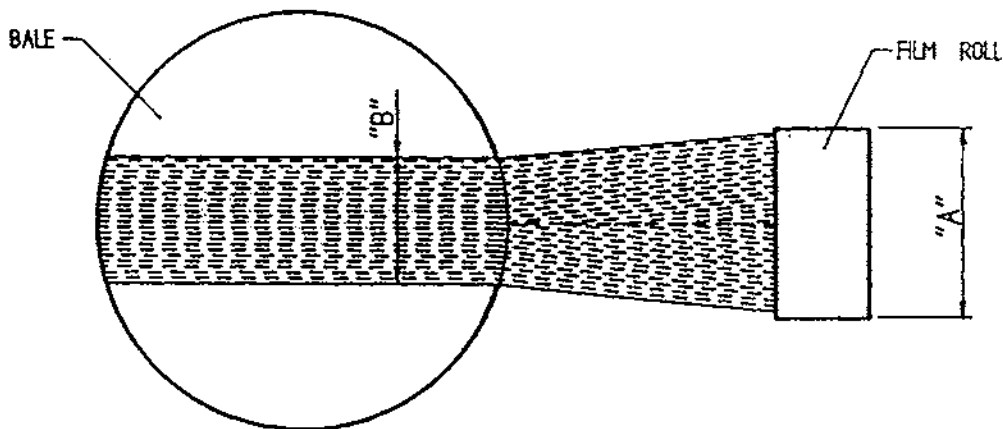

FILM ROLL WIDTH "A"	FILM WIDTH ON END OF BALE "B"
500 mm	400 mm
750 mm	600 mm

Fig. 1

FILE NAME W060-LA21

# TANCO AUTOWRAP TURNTABLE CHAIN DRIVE TENSIONING SYSTEM

## TENSIONING PROCEDURE

1. TIP UP MACHINE AND SUPPORT WITH A PROP.
2. REMOVE CHAIN GUARD.
3. SLACKEN M12 CLAMPING BOLTS SLIGHTLY.
4. SLACKEN LOCKNUT A.
5. ADJUST NUT B UNTIL THERE IS 8mm-10mm DEFLECTION ON CHAIN.

NOTE WARNING:  
DO NOT OVER TENSION CHAIN AS MOTOR WILL BE DAMAGED

6. TIGHTEN LOCKNUT A.
7. TIGHTEN M12 CLAMPING BOLTS.
8. REFIT CHAIN GUARD.

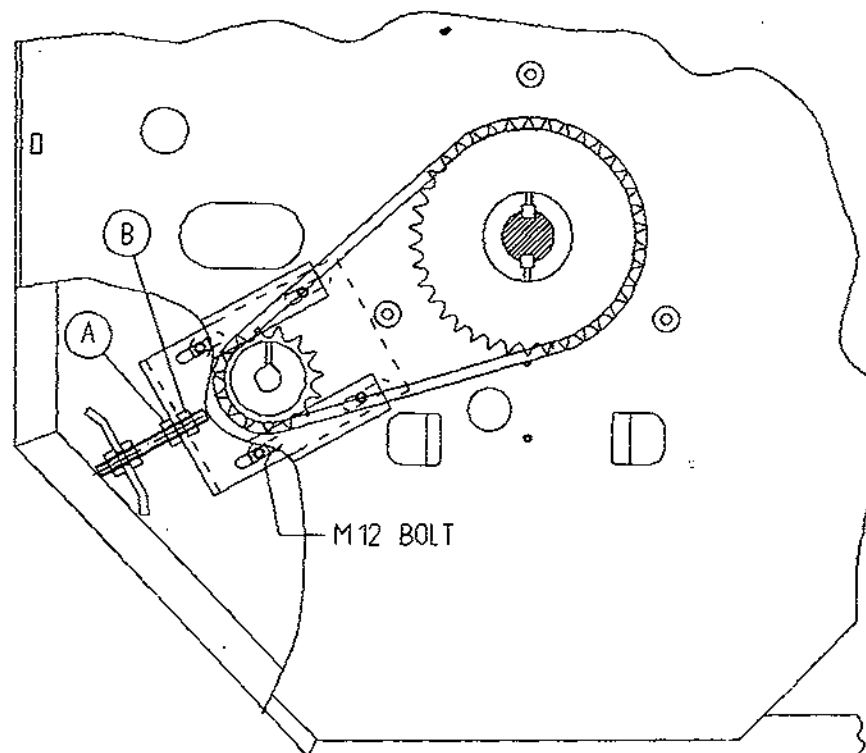
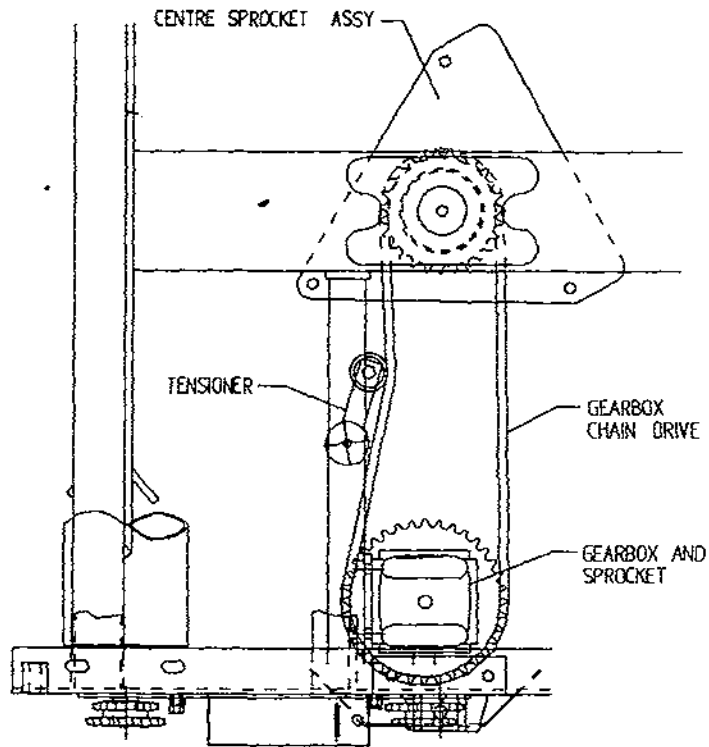

Fig. 8

## TANCO AUTOWRAP CONSTANT INDEXING GEARBOX CHAIN DRIVE TENSIONING SYSTEM



### CHAIN TENSIONING PROCEDURE

1. LOOSEN M10 BOLT SECURING CHAIN TENSIONER.
2. TENSION CHAIN BY ADJUSTING TENSIONER USING SPANNER IN DIRECTION OF ARROW "X" UNTIL SETTING OF 15"-20" IS REACHED.
3. RE-TIGHTEN M10 BOLT TO SECURE TENSIONER IN POSITION.

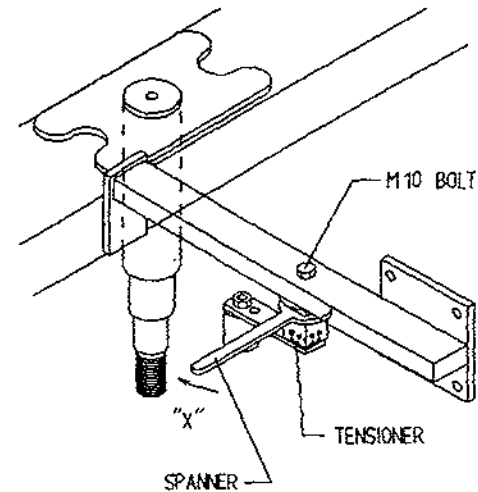
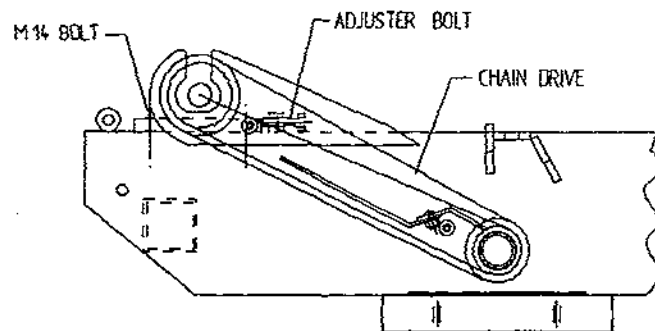

Fig. 2



### ROLLER CHAIN DRIVE TENSIONING SYSTEM

#### CHAIN TENSIONING PROCEDURE

1. LOOSEN M14 BOLTS SECURING BEARING.
2. TENSION CHAIN BY LOOSENING LOCKING NUT AND TURNING ADJUSTER BOLT CLOCKWISE TO TAKE UP SLACK IN CHAIN. SECURE IN POSITION WITH LOCKING NUT. ENSURE EQUAL ADJUSTMENTS ARE MADE ON BOTH SIDES.
3. RE-TIGHTEN M14 BOLTS SECURING BEARINGS TO 170 Nm (125 FT. lbs).

Fig. 3



## ADJUSTMENT TO USE 500MM WIDE ROLLS OF FILM.

All Autowrap models use 750mm wide film rolls as standard. If however, it is found necessary to use 500mm wide rolls, the following instructions must be adhered to:-

**Note:** Failure to do so will result in inadequate wrapping and bale spoilage.

- 1: Slacken locknut and bolt clamping lower film spool. Raise spool so that the bolt clamps in the notch on the spool. Tighten bolt and locknut.  
Set roll of film on lower spool, drop top spool into film core and clamp in place.
- 2: Remove drive chain from inner set of sprockets and fit to outer set of sprockets as shown in Fig. below.
- 3: Re-tension chain.
- 4: Adjust bale wrap indicator setting from 17 to 25 revolutions for 120cm x 120cm bales. (See Table 1 for guide to bale wrap indicator settings).

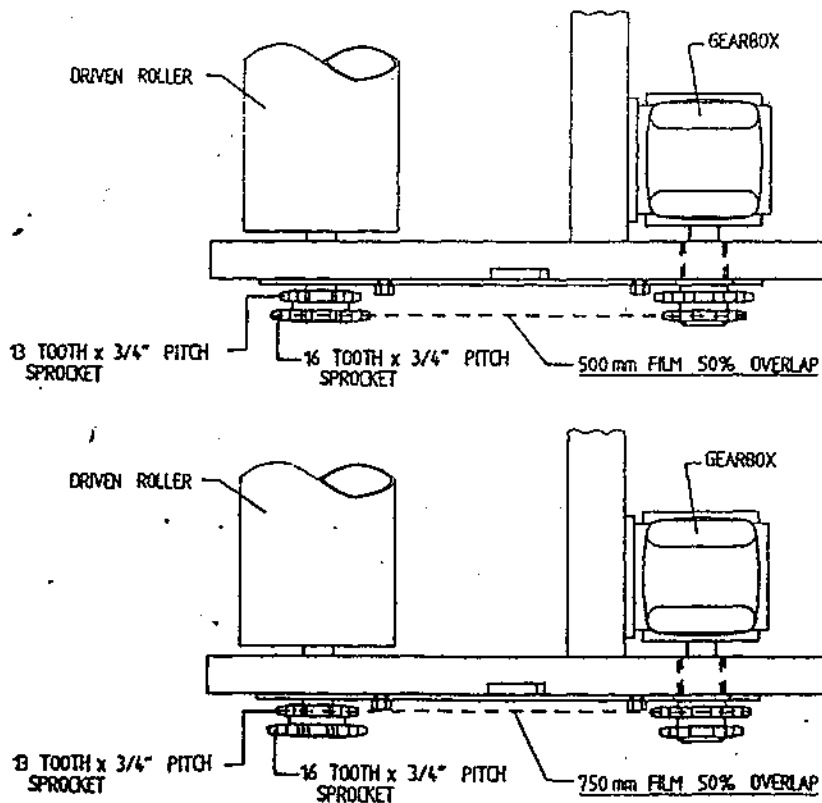
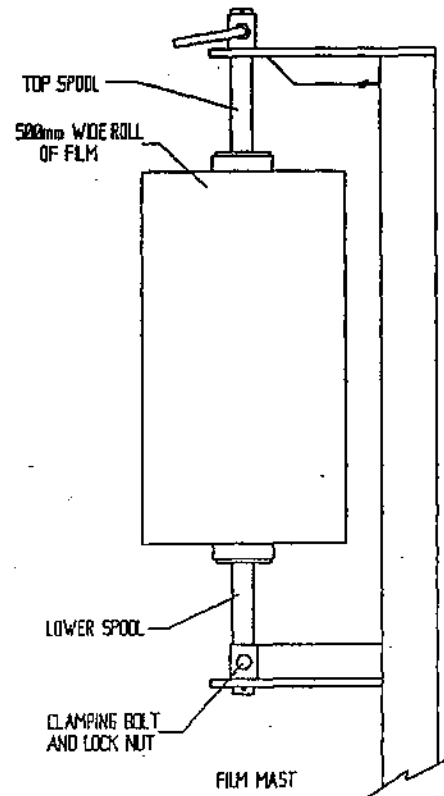

TANCO AUTOWRAP 550S/1060S MODELS  
HYDRAULIC CUT AND START  
ELECTRICAL COMPONENTS

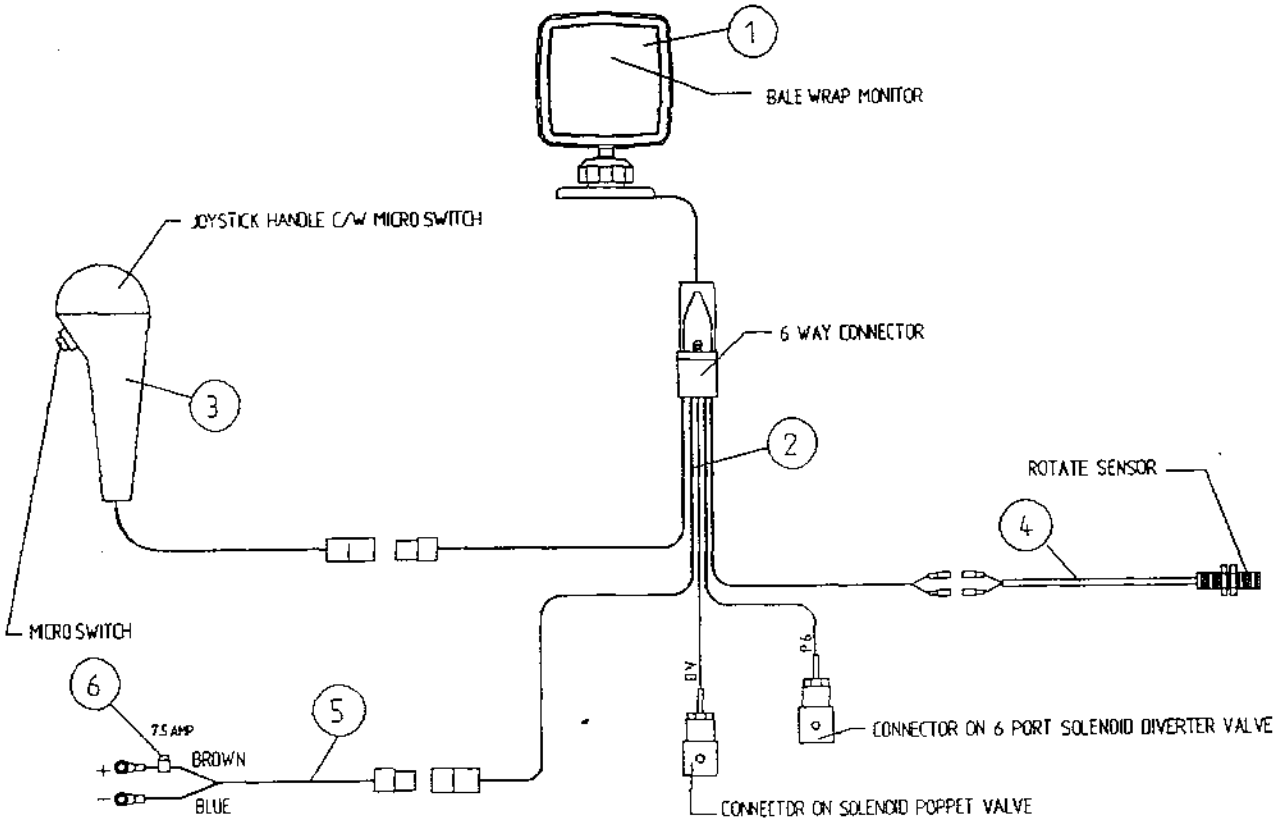

PARTS LIST

ITEM	DESCRIPTION	QTY	PART NO.
1	BALE WRAP MONITOR	1	D604-SCH
2	WIRING LOOM	1	ZD606-HC
3	JOYSTICK KNOB/ SWITCH	1	ZD604-SCH
4	ROTATE SENSOR	1	ZD604SCH4
5	POWER CABLE	1	ZD604-SCH
6	8 AMP FUSE	1	ZD606-108

## TANCO AUTOWRAP 550 S MODEL HYDRAULIC CIRCUIT DIAGRAM

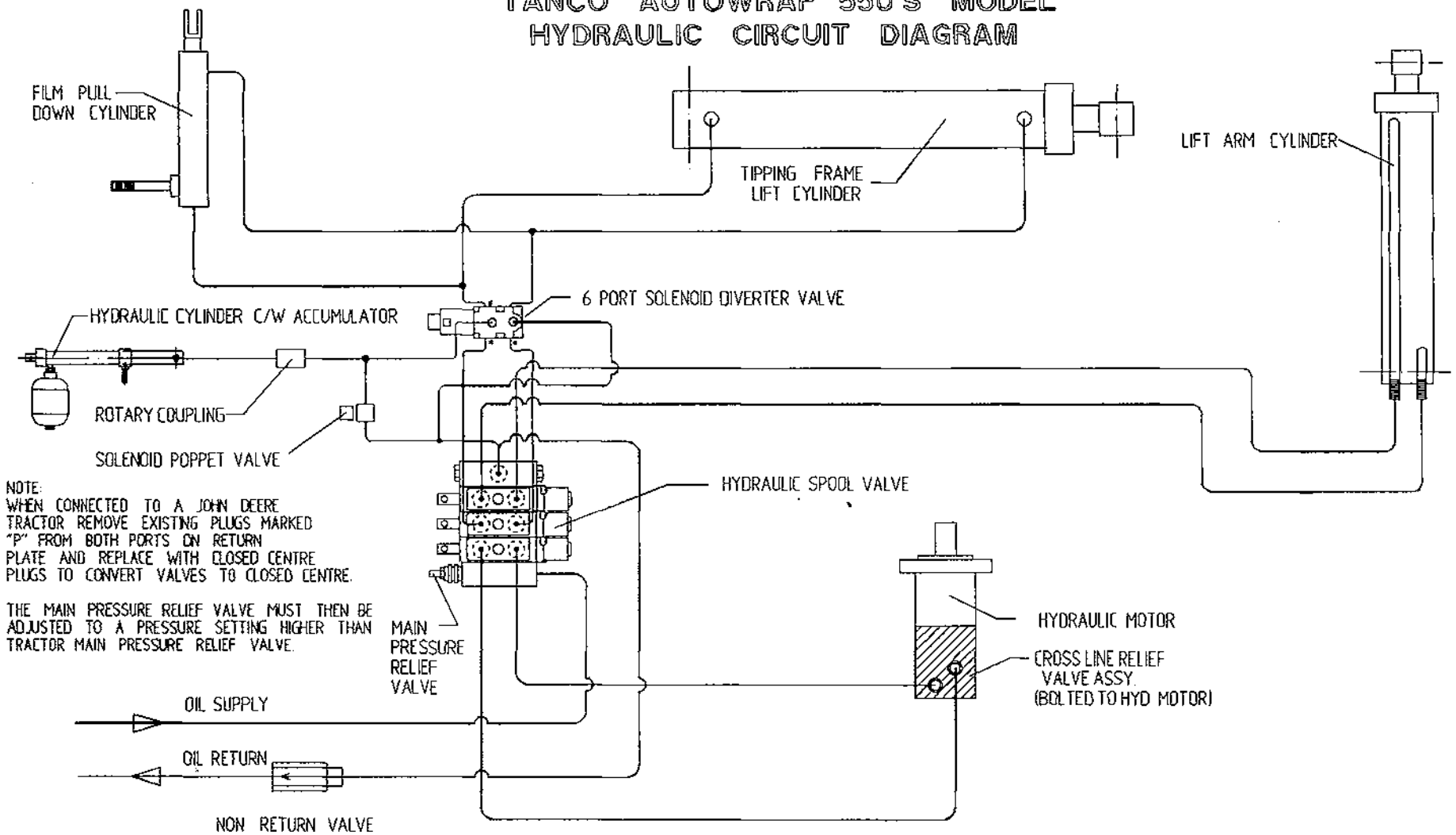

NOTE:  
WHEN CONNECTED TO A JOHN DEERE TRACTOR REMOVE EXISTING PLUGS MARKED "P" FROM BOTH PORTS ON RETURN PLATE AND REPLACE WITH CLOSED CENTRE PLUGS TO CONVERT VALVES TO CLOSED CENTRE.

THE MAIN PRESSURE RELIEF VALVE MUST THEN BE ADJUSTED TO A PRESSURE SETTING HIGHER THAN TRACTOR MAIN PRESSURE RELIEF VALVE.

# TANCO AUTOWRAP 550 S/1060 S MODELS HYDRAULIC COMPONENTS

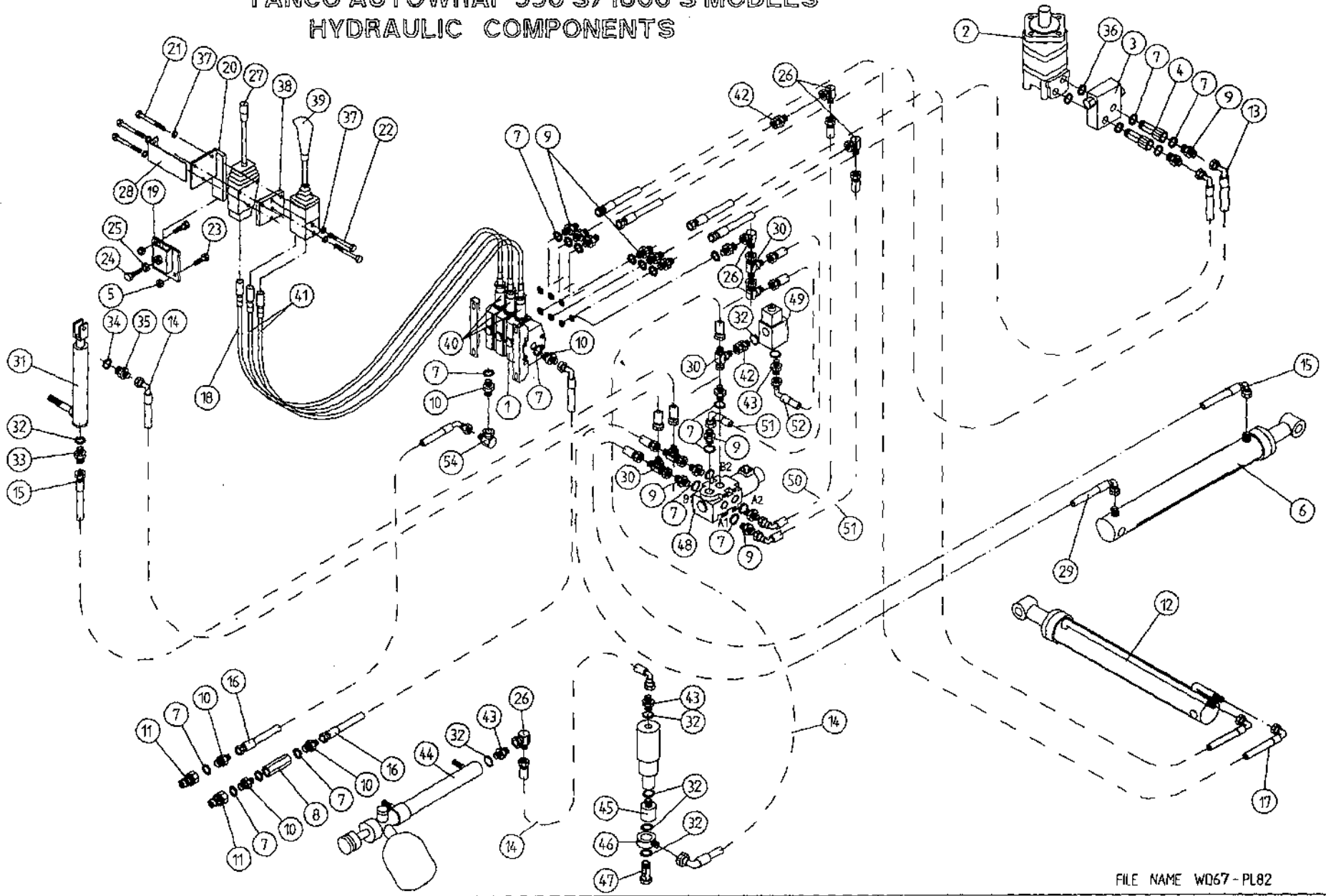

## TANCO AUTOWRAP 550-S/1060-S MODEL HYDRAULIC COMPONENTS

## PARTS LIST

ITEM NO	DESCRIPTION	QTY.	PART-NO
1	3 BANK SPOOL VALVE (DIN)	1	Z01-03-018D
1	HYDRAULIC MOTOR (CL)	1	Z01-02-RF200
1	CROSS LINE RELIEF VALVE	1	ZO 1-03-004
1	1/2" BSP BOTTOM BANJO BOLT (SPECIAL)	2	Z01-03-002B
1	M10 LOCKNUT	3	Z23-1 0
1	HYD. RAM (FOR TIPPING FRAME)	1	Z01-01AR687
1	1/2" DOVITY WASHERS	18	Z01-04-03
1	1/2" NON RETURN VALVE	1	Z01-03-017
1	1/2" X 3/8" ADAPTOR	10	Z01-06-06-08
10	1/2" X 1/2" ADAPTOR	5	Z01-06-08-08
11	1/2" MALE END Q/R COUPLING	1	Z01-15-081
12	HYD RAM (FOR LIFT ARM)	1	Z01-01-AW
13	108" ST/90 3/8" D/W HOSE	3	Z38-R2-108-Sg
14	72" ST/90 3/8" D/W HOSE	2	Z38-R2-72-Sg
15	48" ST/90 3/8" D/W HOSE	1	Z38-R2-48-Sg
16	108" ST/90 1/2" D/W HOSE	2	Z12-R1-108-Sg
17	84" ST/90 3/8" D/W HOSE	1	Z38-R2-84-S9
18	3.5M ACTUATOR CABLES	1	Z004-03-0075
19	ACTUATOR MTG BRACKET (LOWER)	1	WD65-AML
20	ACTUATOR MTG BRACKET (UPPER)	1	WD65-AMU
21	M8X 60 HEX BOLT	3	Z26-047B
22	M8X70 HEX BOLT	1	Z26-049B
23	M10 HEX HD SETS X 40MM LONG	3	Z26-064S
24	M12 HEX HD SET X 40MM LONG	1	Z26-084S
25	M12 HEX NUT	1	Z1 8-12
26	3/8" MALE X 3/8" FEMALE 90 ELBOW	5	Z01-14-015
27	ACTUATOR LEVERS	1	Z004-03-009
28	STICKER MOUNTING PLATE	1	WD60-794
29	60" ST/90 3/8" D/W HOSE	1	Z38-R2-60-S9
30	3/8" FEMALE X 3/8" MALE/MALE "T" PIECE	4	Z01-12-002
31	HYDRAULIC RAM D/A	1	Z01-01-AW25
32	3/8" DOWTY WASHER	1	Z01-04-02
33	3/8" X 3/8" ADAPTOR FITTED WITH 0.06" RESTRICTOR	1	Z01-03-40
34	1/4" DOWTY WASHER	1	Z01-04-01
35	1/4" X 3/8" ADAPTOR	1	Z01-06-04-06
36	COPPER WASHER	1	Z01-04-15
37	8MM SPRING WASHER	1	Z1 2-02-08
38	ACTUATOR/JOYSTICK ADAPTOR PLATE	1	AY1 5-072
39	JOYSTICK ACTUATOR	1	Z004-03-013
40	CABLE FITTING KIT DIN OIL	3	Z004-03-014
41	3.5M JOYSTICK CABLE	1	Z004-03-00753
42	3/8" M/F ADAPTOR	1	Z01-05-06-06
43	3/8" MALE/MALE ADAPTOR	1	Z01-06-06-06
44	CUT AND START	1	Z01-01-ANH
45	ROTARY COUPLING	1	Z01-02-AWR
46	3/8" BANJO COUPLING	1	Z01-19-062
47	3/8" SINGLE TOP BANJO BOLT	1	Z01-20-062
48	6 PORT SOLENOID VALVE	1	Z01-03-103
49	2 PORT SOLENOID POPPET VALVE	1	Z01-03-103
50	30" ST/90 3/8" DW HSE	2	Z38-R2-30-59
51	18" ST/90 3/8" DW HOSE	1	Z38-R2-18-Sg
52	14" ST/90 3/8" DW HOSE	1	Z38-R2-14-Sg
53	96" ST/90 3/8" DW HOSE	1	Z38-R2-96-Sg
54	1/2" MALE X 1/2" FEMALE ELBOW	1	Z01-14-016

TANCO AUTOWRAP

CONSTANT INDEXING DRIVE ASSY

NOTE:  
ITEMS MARKED WITH \* DENOTES ITEMS  
REQUIRED FOR AUTOMATIC MODELS ONLY.

36

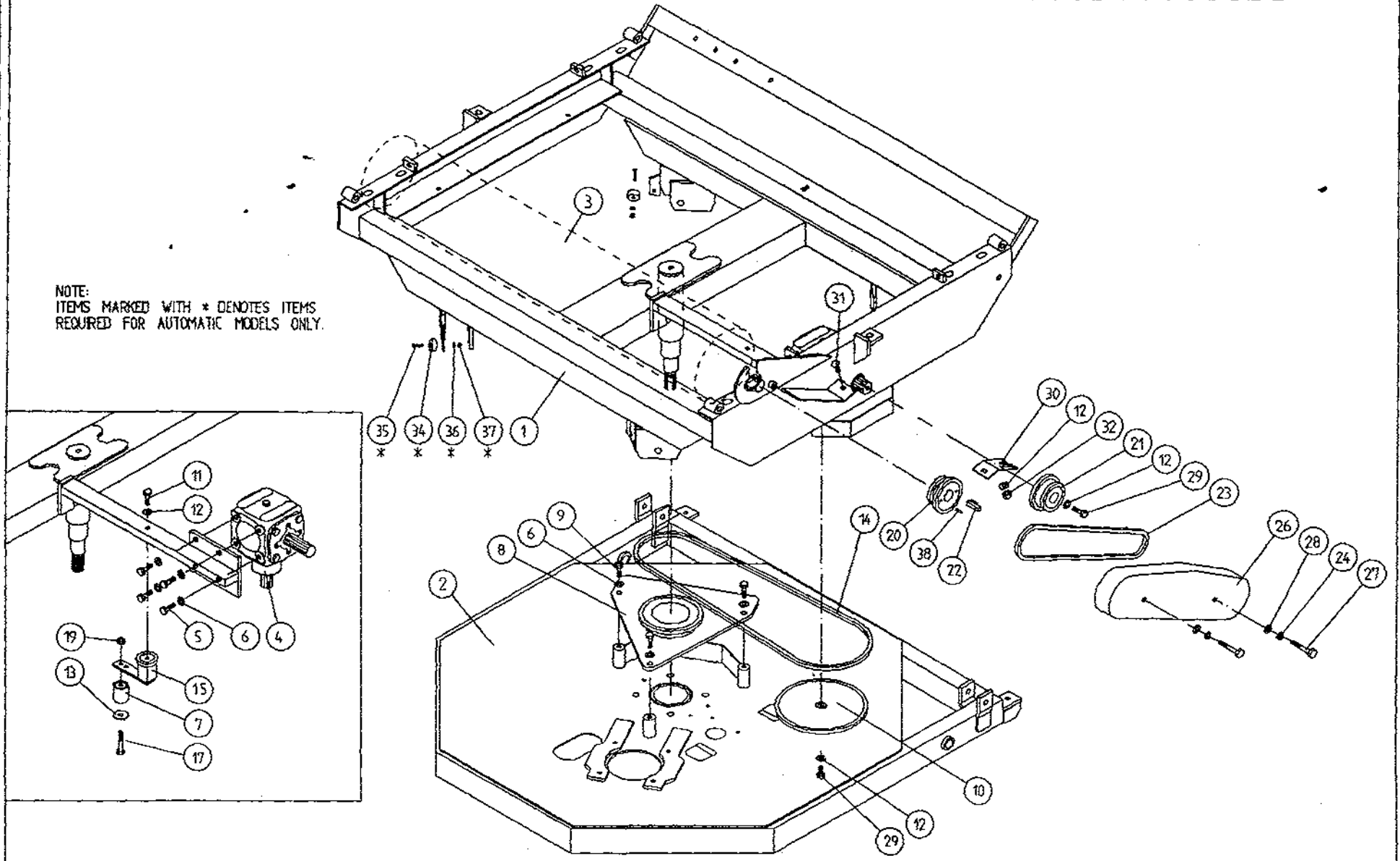

TANCO AUTOWRAP  
CONSTANT INDEXING DRIVE ASSEMBLY

PARTS LIST

ITEM NO.	DESCRIPTION	QTY.	PART-NO
1	TURNTABLE ASSY.	1	WD66-TA
2	TIPPING FRAME ASSY.	1	WD64-TF
3	DRIVE ROLLER ASSY.	1	WD66-BRD
4	GEAR BOX	1	Z01-25-300
5	M12 HEX HD SET x 30mm LONG	4	Z26-082S
6	12mm DIA SPRING WASHER	7	Z12-02-12
7	CHAIN TENSIONER	1	WD60-CT
8	CENTRE SPROCKET ASSY 27 TOOTH	1	WD64-CSA
9	M12 HEX HD SET x 25mm LONG	3	Z26-081S
10	46 TOOTH SPROCKET	1	Z06-D64-46S
11	M10 HEX HD SET x 25mm LONG	1	Z26-0611S
12	10mm DIA SPRING WASHER	4	Z12-02-10
13	RETAINING COLLAR	1	WD623-071
14	CHAIN 3/4" PITCH X 87 PITCHES	1	Z09-AW-5
15	ROSTA TENSIONING UNIT ARM	1	Z06-454
17	M10 HEX HD BOLT x 65mm LONG	1	Z26-0671B
19	M10 LOCKNUT	1	Z23-10
20	SPROCKET DOUBLE SIMPLEX 13T/16T KEYED	1	Z06-D64-1316K
21	SPROCKET DOUBLE SIMPLEX 13T/16T SPLINED	1	Z06-D65-1316S
22	KEY 5/16" x 5/16" x 32mm LONG	1	WD623-K32
23	CHAIN 3/4" PITCH X 62 PITCHES	1	Z09-AW-3
24	1/2" DIA STAR WASHER	2	Z10-01-121
26	CHAIN GUARD	1	WD60-CGC
27	M10 HEX HD SET x 70mm LONG	2	Z26-068B
28	10mm DIA FLAT WASHER	2	Z10-02-10
29	M10 HEX HD SET x 30mm LONG	2	Z26-062S
30	CHAIN STRIPPER	1	WD66-053
31	M10 CUP SQ. SCREW x 30mm LONG	1	Z13-112
32	M10 HEX NUT	1	Z18-10
34*	MAGNET	2	D6043
35*	M6 CSK HD SET x 35mm LONG	2	Z13-132
36*	6mm DIA FLAT WASHER	2	Z11-02-06
37*	M6 LOCKNUT	2	Z23-06
38	SPIRAL PIN	2	Z03-23-062

\* DENOTE ADDITIONAL ITEMS REQUIRED FOR AUTOMATIC MACHINES

# TANCO AUTOWRAP 550S/550A MODELS

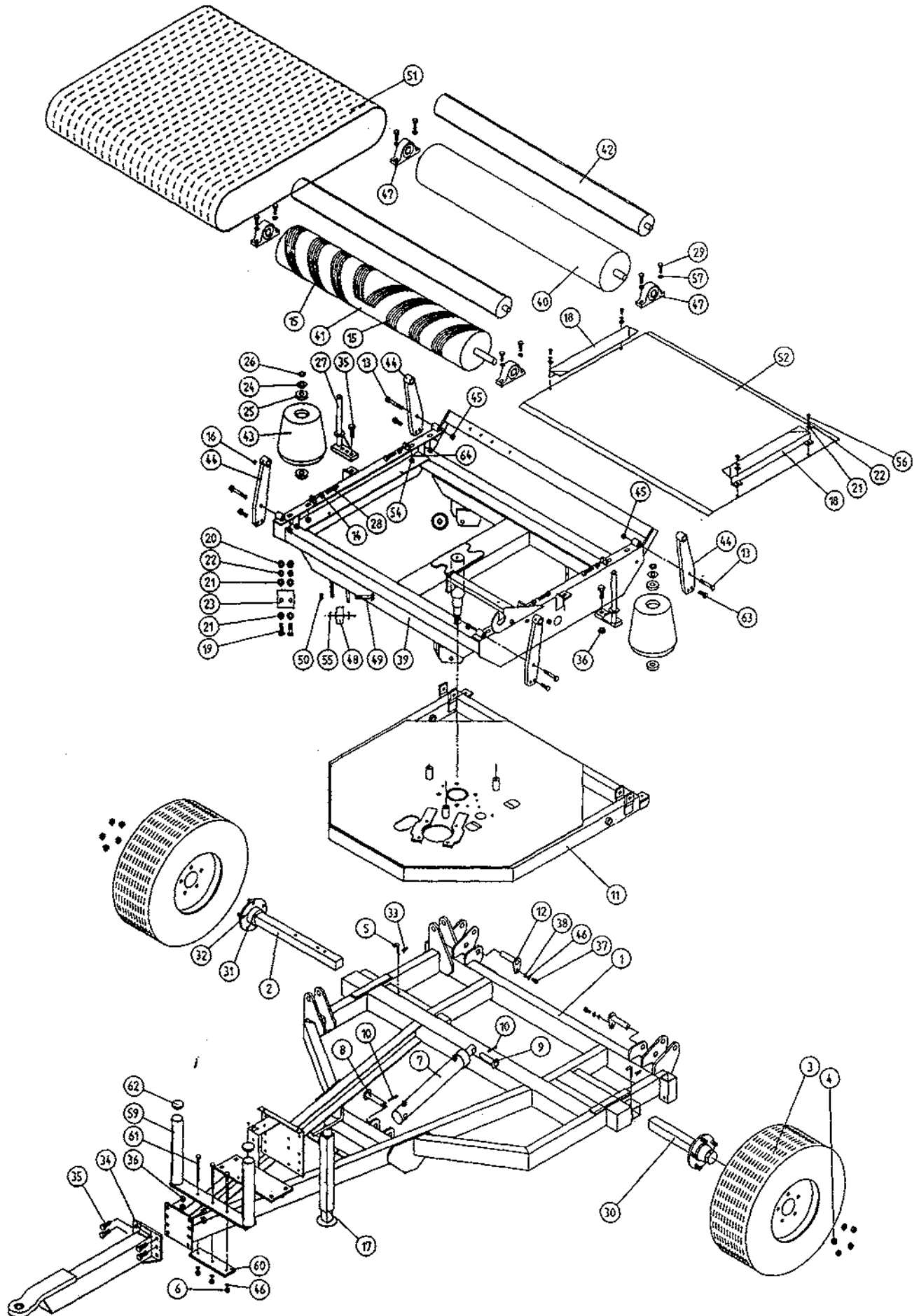

FILE NAME WD 67 PL 44



## TANCO AUTOWRAP 350S/550S/650A MODELS (TRAILED)

ITEM NO:	PARTS LIST	QTY	PART NO.
1	CHASSIS ASSY	1	WD66-CHA
2	STUB AXLE (LONG)	1	Z04-0336
3	WHEELS (STANDARD WIDTH)	2	Z04-03
	(WIDE)		Z04-04
4	WHEELS NUTS	10	M22AWNA
5	BISSEL PIN	2	Z03-22-AW82
6	M10 HEX NUT	3	Z18-10
7	HYDRAULIC RAM	1	Z01-01-AR687
8	RAM BOTTOM PIVOT PIN	1	Z03-02-330
9	RAM TOP PIVOT PIN	1	Z03-03-50
10	2" X 1/4" SPLIT PIN	2	Z03-21-29
11	TIPPING FRAME ASSEMBLY	1	WD64-TF
12	TIPPING FRAME PIVOT PIN C/W GREASE NIPPLE	2	Z03-01-9055
			Z39-60
13	M12 HEX HD BOLT X 80MM LONG	4	Z26-0901B
14	M12 HEX NUT	4	Z16-12
15	GRIP FACE KIT	2	Z05-02-AW49
16	1/8" B.S.P. ST GREASE NIPPLE	4	Z39-60
17	SCREW JACK ASSEMBLY (WELDED ON)	1	WD60-JA
18	BELT GUIDE ASSEMBLY	2	WD66-BG
19	M8 HEX HD SETS X 20MM LONG	4	Z26-039S
20	M8 HEX NUTS	14	Z18-08
21	8MM DIA FLAT WASHERS (MUD FLAP)	8	Z11-02-081
22	8MM DIA SPRING WASHERS	12	Z12-02-08
23	SCRAPER	2	WD60-711
24	THRUST WASHER	2	WD60-292
25	BEARING (25MM I.D.)	4	Z06-AWRB-93
26	CIRCLIP	2	Z28-525
27	END ROLLER MOUNTING BRACKET	2	WD66-ERH
28	M12 HEX HD SET X 60MM LONG	4	Z26-088S
29	M14 HEX HD SET X 55MM LONG	8	Z26-105S
30	STUB AXLE (SHORT)	1	Z04-032
31	INNER BEARINGS	2	M22AB-209
32	OUTER BEARINGS	2	M22AB-206
33	4MM 'R' CLIP	2	Z36-02
34	RING HITCH ASSY (LONG)	1	WD65-HIT
35	M16 HEX HD SET X 50MM LONG	6	ZZG-124S
36	M16 LOCKNUTS	6	Z23-16
37	M10 HEX HD SET X 25MM LONG	2	Z26-061S
38	10MM DIA MACHINED FLAT WASHER	2	Z11-02-10
39	TURN TABLE ASSY	1	WD67-TA
40	BELT ROLLER ASSY IDLER	1	WD66-BRI
41	BELT ROLLER ASSY DRIVER	1	WD66-BRD
42	SMALL ROLLER ASSY	2	WD66-SMR
43	SIDE ROLLER	2	Z06-AWR
44	ROLLER MOUNTING BRACKET	4	WD66-RMB
45	M12 LOCKNUTS	8	Z23-12
46	10MM DIA SPRING WASHER	5	Z12-02-10
47	1 1/4" PILLOW BLOCK BEARING C/W CAM LOCK COLLAR	4	Z06-485
48	SUPPORT WHEELS (4" DIA)	4	Z06-486
49	AXLE ASSY C/W GREASE NIPPLE	4	Z03-22-AW/AX
			Z39-60
50	M20 LOCKNUTS	4	Z23-20
51	1200 WIDE X 2475MM LONG X 1/4" FLAT BELT	1	Z05-02AW96
52	TURN TABLE COVER PLATE	1	WD66-043
54	M14 HEX NUT	4	Z18-14
55	SPACER	8	WD60-198
56	M8 HEX HD SET X 30MM LONG	4	Z26-041S
57	14MM DIA FLAT WASHER	8	Z11-02-14
59	FILM TRANSPORT BRACKET	1	WD60-FTB1
60	CLAMPING PLATE	1	WD60-933
61	M10 HEX HD BOLT X 140MM LONG	3	Z26-0726S
62	PLASTIC CAP	2	Z32-08
63	M12 HEX HD SET X 40MM LONG	4	Z26-084S
64	14MM DIA SPRING WASHER	4	Z12-02-14



TANCO AUTOWRAP  
TURNTABLE CHAIN DRIVE ASSEMBLY

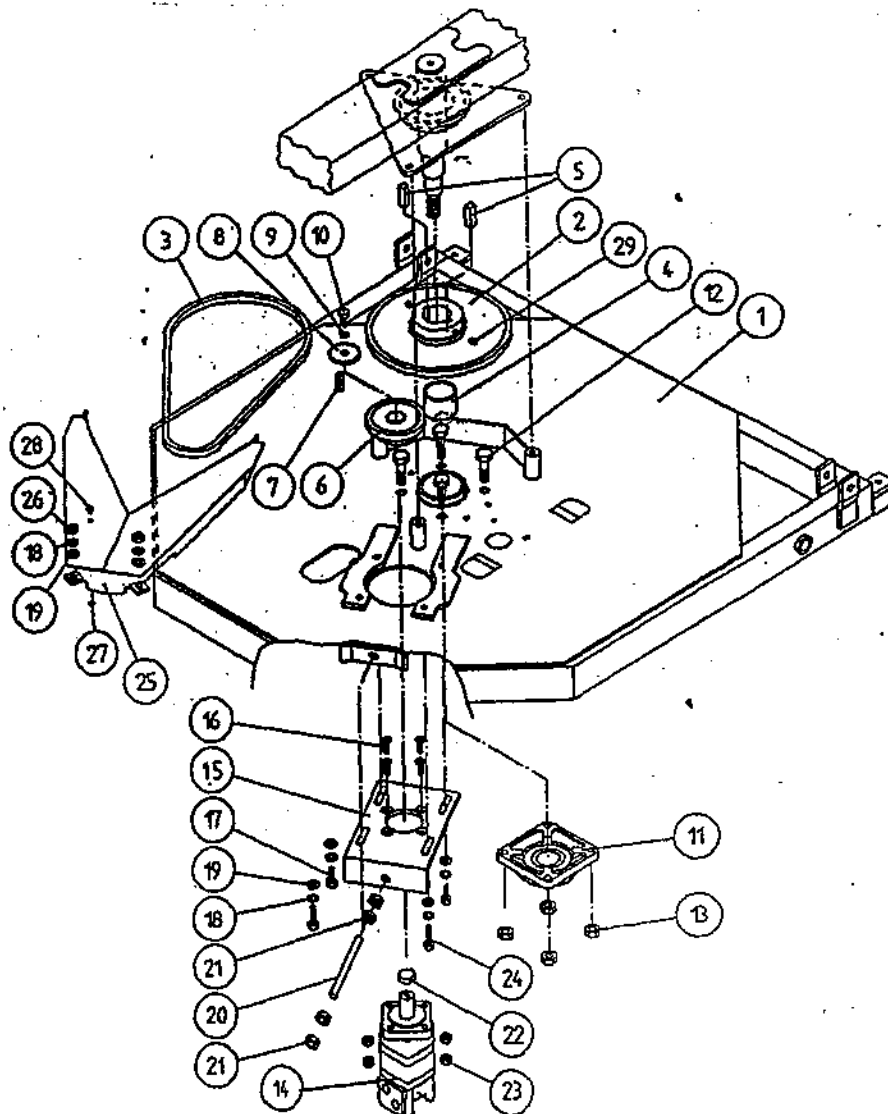

PARTS LIST

ITEM NO	DESCRIPTION	QTY	PART NO
1	TIPPING FRAME ASSY	1	WD64-TF
2	38 TOOTH x 1" PITCH SPROCKET	1	Z06-D64-38
3	CHAIN 1" PITCH x 54 PITCHES	1	Z09-AW6
4	SPINDLE SPACER	1	WD64-040
5	KEY 5/8" SQ x 50mm LONG	2	WD64-052
6	15 TOOTH x 1" PITCH SPROCKET	1	Z06-I60-046
7	KEY 5/16" SQ x 45mm LONG	1	WD64-053
8	LOCKING COLLAR	1	WD623-071
9	10mm DIA SPRING WASHER	1	Z12-02-10
10	3/8" UNC HEX HD SET x 1" LONG	1	Z27-023S
11	2" DIA FLANGE BEARING C/W CAM LOCK COLLAR	1	Z06-49EC
12	5/8" UNF HEX HD SET x 2" LONG	4	Z31B-064
13	5/8" UNF LOCKNUT	4	Z20-10
14	HYDRAULIC MOTOR	1	Z01-02-RF200
15	HYDRAULIC MOTOR MOUNTING PLATE	1	WD64-001
16	M12 x 50mm ALLEN HD O/S SCREW	4	Z13-5-12X50
17	M12 HEX HD SET x 30mm LONG	4	Z26-082S
18	12mm DIA SPRING WASHER	4	Z12-02-12
19	12mm DIA FLAT WASHER	4	Z10-02-12
20	M16 THREADED BAR x 150mm LONG	1	WD64-038
21	M16 HEX NUTS	4	Z18-16
22	SPACER	1	WI60-093
23	M12 LOCKNUTS	4	Z23-12
24	M12 HEX HD SET x 50mm LONG	2	Z26-086S
25	DRIVE CHAIN GUARD	2	WD66-DCG
26	M12 HEX NUT	2	Z18-12
27	M6 HEX NUT	1	Z18-06
28	M6 90 DEGREE GREASE NIPPLE	1	Z39-65

**TANCO AUTOWRAP 350S / 550S / 550A MODELS  
LIFT ARM AND CHASSIS**

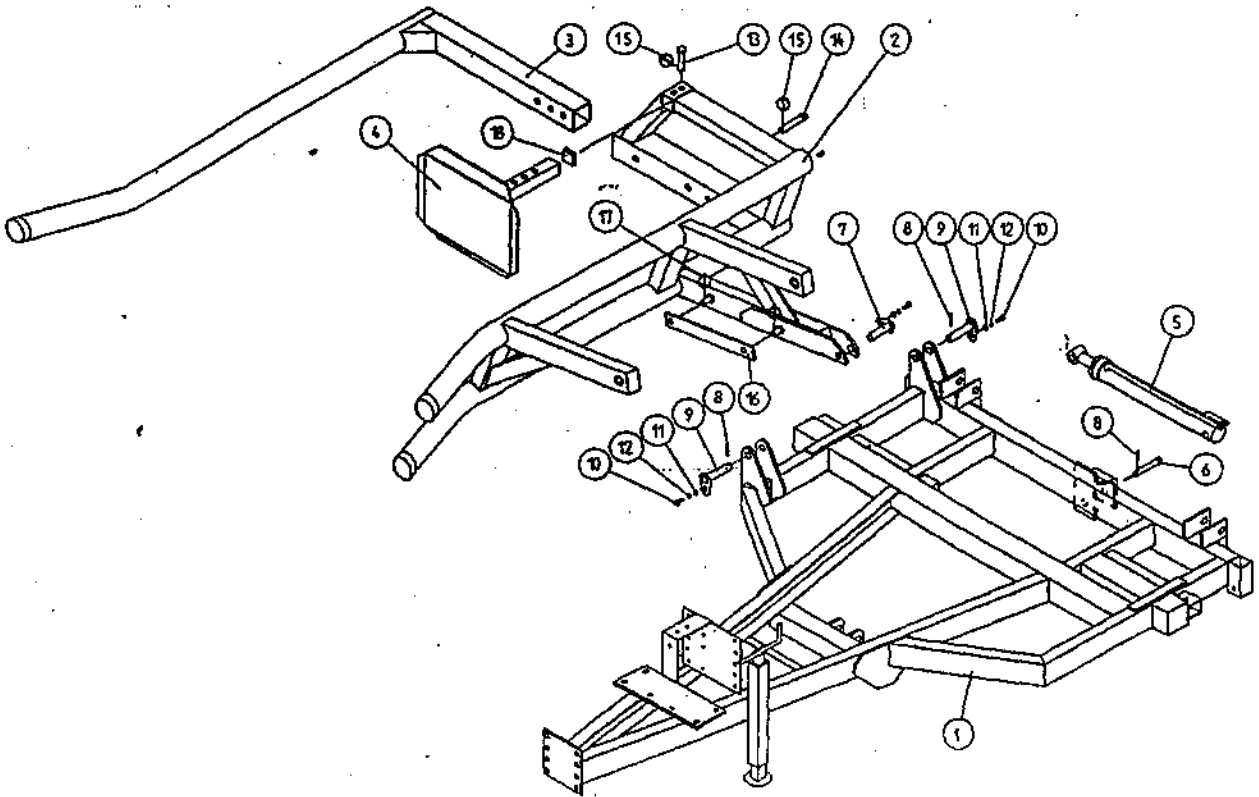

**PARTS LIST**

ITEM NO	DESCRIPTION	QTY	PART NO.
1	CHASSIS ASSEMBLY	1	WD67-CHA
2	LIFT ARM ASSEMBLY	1	WD60-LA
3	ADJUSTABLE OUTER ARM ASSEMBLY	1	WD60-LAAA
4	ADJUSTABLE BALE STOP	1	WD610-LAS
5	HYDRAULIC RAM (LIFT ARM)	1	Z01-01-AW
6	RAM BOTTOM PIVOT PIN	1	Z03-02-330
7	RAM TOP PIVOT PIN	1	Z03-01-905A
8	2" X 1/4" SPLIT PINS	3	Z03-21-29
9	LIFT ARM PIVOT C/W GREASE NIPPLE	2	Z03-01-905
10	M10 HEX HD SET X 25MM LONG (TUFLOCK)	3	Z26-061S
11	10MM DIA MACHINED FLAT WASHER	3	Z11-02-10
12	10MM DIA SPRING WASHER	3	Z12-02-10
13	SPAREX PIN	1	Z03-04-73
14	SPAREX PIN	1	Z03-04-77
15	7/16" DIA LINCH PINS	2	Z03-22-06
16	SAFETY SUPPORT BAR	1	WD60-319
17	6MM DIA LINCH PIN	2	Z03-22-03
18	PLASTIC CAP	1	Z32-10

## FAULT FINDING

PROBLEMS.	REMEDY.
1. Drive Roller and Bale belt not driving	Check and replace shear Pins in sprocket on drive roller.
2. Film Breaking	Wash off dispenser and slave rollers. Change roll of film. Use recommended films only.
3. Film not wrapping evenly on bale.	Adjust film mast so centre of film roll is aligned with centre of bale .
4. Film Tearing on Ramp.	Check for sharp edges and remove.
5. Bale Skidding on Ramp.	Fit Hessian Bag or piece of carpet to Ramp.
6. Film Dispenser not Pre-Stretching Film.	Check that both Rollers turn when one is turned by hand. If not, fit new gears or replace unit.
7. Tyres coming off 4" platform Support Wheels.	Replace Wheels - Reduce speed below 30 r.p.m. - Do not grease path of wheels on platform. Check that bale does not get trapped between arms and turntable when being loaded.  If this happens lower arm and start again.
8. Hydraulic Bale Ramp not returning to raised position after tipping off bale.	See instructions for recharging hydraulic cylinder.
9. Bale Belt Tracking Adjustment	
(i) Ensure vertical rollers (plastic) are in tight on the bale. Remember that the bale will reduce in size during wrapping and, on the round bales in particular, the corners will become rounded so that the bale will tend to move sideways due to centrifugal forces. Now, if the plastic rollers are too far apart, the bale will move against one of the plastic rollers causing the belt to move in the opposite direction. Always adjust the vertical plastic rollers so that they keep the bale central on the belt.	
(ii) Adjust bale stop on lift arm so that bale is loaded centrally onto platform.	
(iii) Check that bale belt is fitted so arrow points in direction of travel.	
(iv) Check that both 8" rollers underneath the bale belt are parallel to each other. Remember the golden rule - a belt will always move up a slope: So, if the belt continually moves to our side, adjust idler roller to a narrower setting on the opposite side to which the belt travels.	
(v) Check that gripface strips are securely fixed to the roller and have not moved out of alignment.	
(vi) Check that is the same measurement each side by running a string around the belt and measuring it. If one side is longer than the other replace the belt.	

TANCO AUTOWRAP  
HYDRAULIC CUT AND START  
MAIN ASSEMBLY

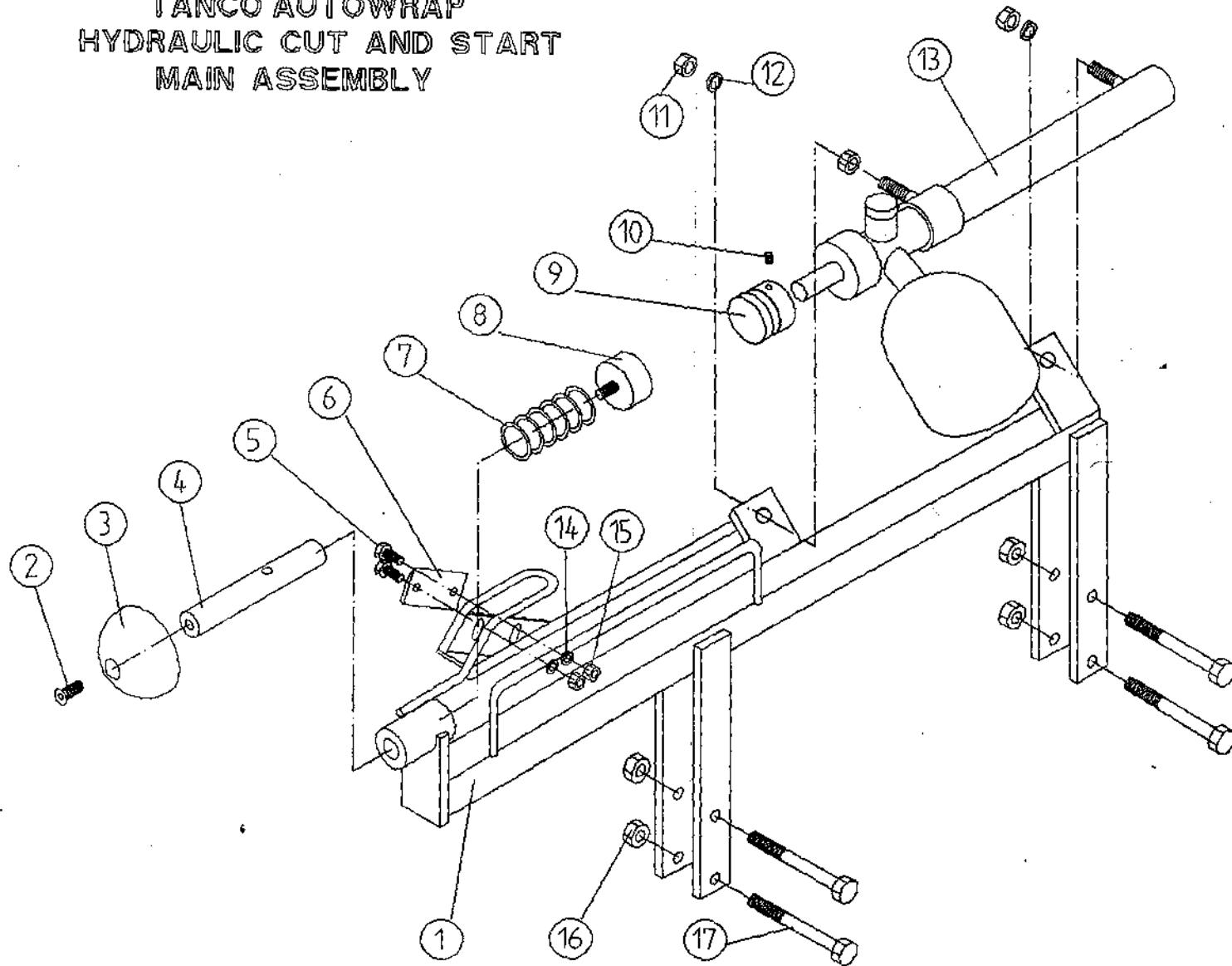

**TANCO AUTOWRAP  
HYDRAULIC CUT AND START UNIT  
PARTS LIST**

**WD67PL80**

<b>TEM NO.</b>	<b>DESCRIPTION</b>	<b>QTY</b>	<b>PART NO.</b>
1	HYDRAULIC CUT AND START MAIN FRAME	1	WD605H-MF
2	H10420 CSK SCREW	1	Z13-139
3	3" DOMED CAP	1	WD605H-14
4	GRIPPER ROD	1	WD605H-13
5	H6 X 25 HEX SET	1	Z26-0405
6	BLADE	1	WD605-104
7	SPRING	1	Z07-49
8	GRIPPER PAD (RUBBER)	1	Z40-28
9	GRIPPER PAD	1	WD605H-15
10	M8 X 10 GRUB SCREW	1	Z28-008
11	M14 HEX NUT	3	Z18-14
12	14MM SPRING WASHER	2	Z12-02-14
13	CUT & START HYDRAULIC RAM ACCUMULATOR	1	Z01-01-AWH
14	8MM FLAT WASHER	2	Z11-02-08
15	M8 LOCK NUT	2	Z23-08
16	M10 LOCK NUT	4	Z23-010
17	M10 X 75 HEX BOLT	4	Z26-069B

# TANCO AUTOWRAP - HYDRAULIC CUT AND START INSTRUCTIONS FOR RECHARGING HYDRAULIC CYLINDER

- 1 REMOVE PLUG FROM PORT "A"
- 2 CONNECT HOSE FROM HYD HAND PUMP TO PORT "A"
- 3 CHARGE CYLINDER TO A PRESSURE OF 60 BAR (870 P.S.I.)
- 4 REMOVE HOSE FROM PORT "A" AND REFIT PLUG.

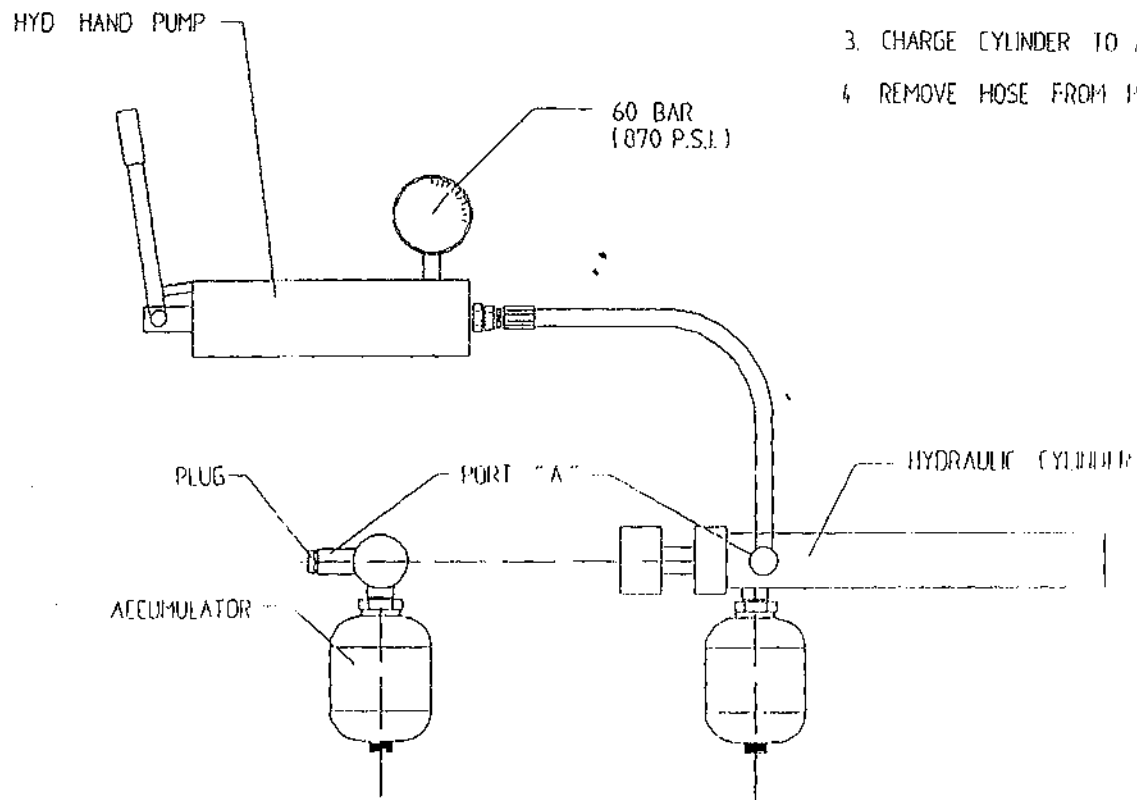

FILE NAME WD67PL-84



WD64 PL41

TANCO AUTOWRAP

TURNTABLE LOCKING ARRANGEMENT

PARTS LIST

ITEM	DESCRIPTION	QTY	PART NO
1	UNDERSIDE OF TIPPING FRAME	1	WD64-TF
2	TURNTABLE CENTRE SHAFT	1	WD64-002
3	SPINDLE SPACER	1	WD67-SS
4	1 1/4" UNC HEX NUT	1	Z18-300
5	M8 GRUB SCREW X 6MM LONG	1	Z28-007

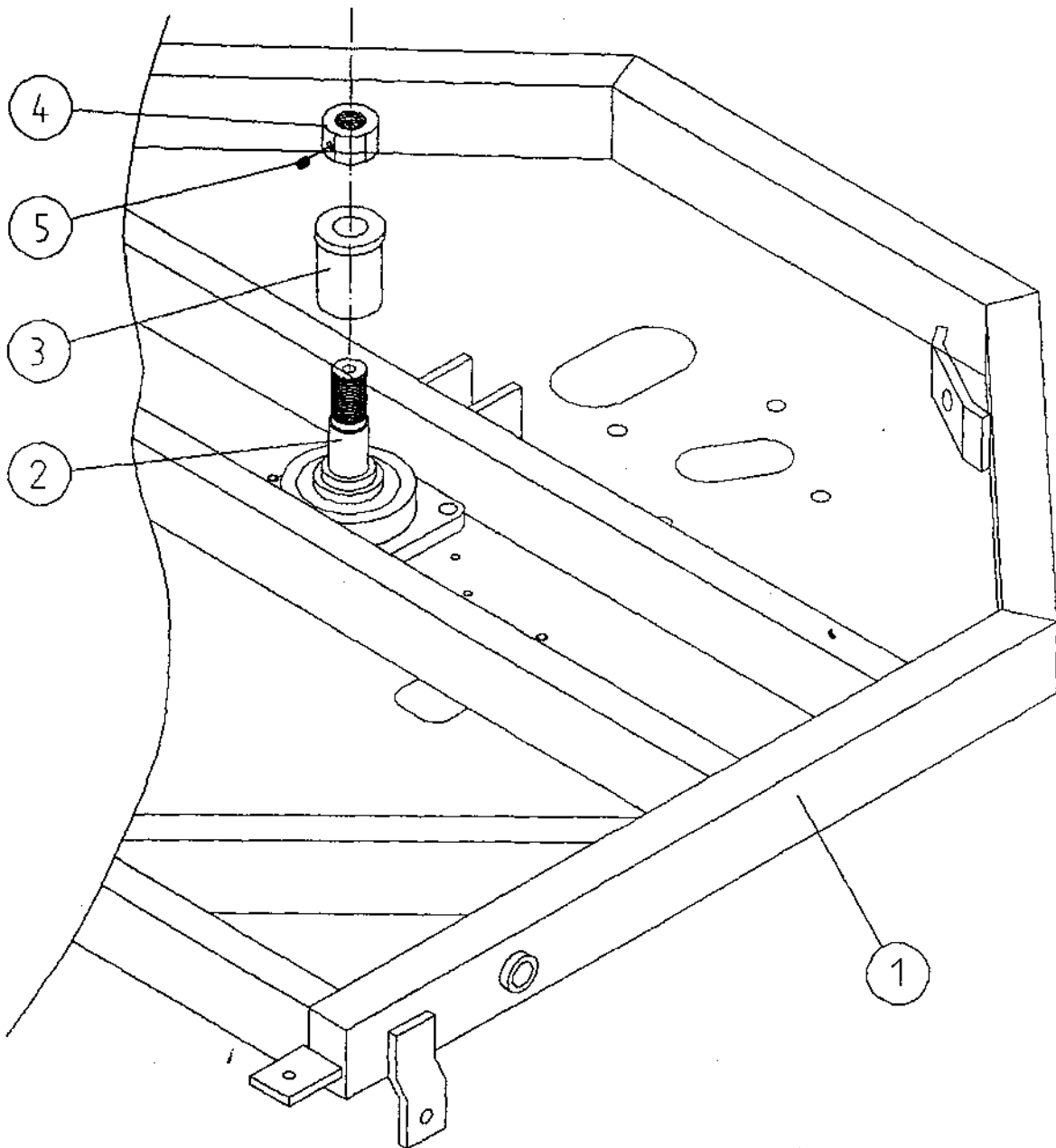

# TANCO AUTOWRAP 550S/550A MODELS FILM DISPENSER SYSTEM

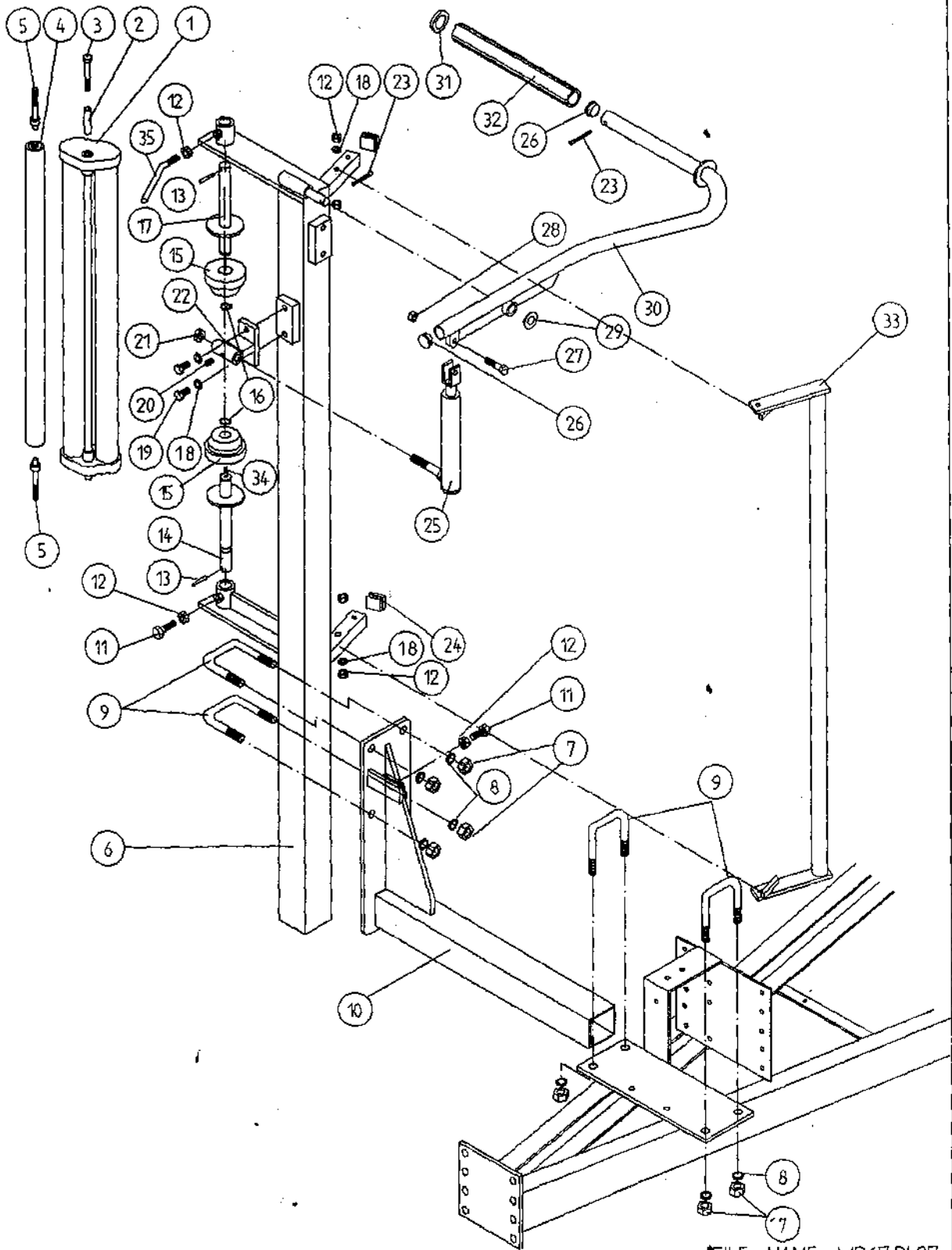

FILE NAME WD67PL27

**TANCO AUTOWRAP 550A/550S MODELS****FILM DISPENSING SYSTEM**  
**PARTS LIST**

ITEM NO:	DESCRIPTION:	QTY:	PART NO:
1	FILM DISPENSER UNIT MK9 (70% STRETCH)	1	D616
2	SLEEVE	1	D52012-95
3	M12 X 80 HEX BOLT	2	Z26-0901B
4	SLAVE ROLLER LONG	1	Z06-SR95-L
5	SLAVE ROLLER PIVOT	2	WD64-SRP
6	DISPENSER MAST	1	WD69-DM
7	M16 HEX NUT	8	Z18-16
8	16MM SPRING WASHER	8	Z12-02-16
9	80MM M16 'U' BOLTS	4	Z35-52
10	DISPENSER MAST MOUNTING BRACKET	1	WD67-DMM
11	M12 X 40 HEX SET	2	Z26-084S
12	M12 HEX NUT	2	Z18-12
13	5 X 45 ROLL PIN	2	Z03-21-15
14	FILM SPOOL LOWER	1	WD67-FSL
15	FILM MAST CONE	2	Z06-45-03
16	CIRCLIP	2	Z28-525
17	FILM SPOOL UPPER	1	WD67-FSU
18	12MM SPRING WASHER	4	Z12-02-12
19	M12 X 30 HEX SET	4	Z26-082S
20	1/8 B.S.P. STRAIGHT GREASE NIPPLE	1	Z39-60
21	M16 LOCKNUT	1	Z23-16
22	FILM PULL DOWN BRACKET ASSEMBLY	1	WD65-FPDB
23	1/4" X 2" SPLIT PIN	2	Z01-23-29
24	PLASTIC CAP	2	Z32-07
25	HYDRAULIC RAM (PULL DOWN)	1	Z01-01-AW25
26	1" G.B. PLASTIC CAP	2	Z32-14
27	M12 X 50 HEX SET	1	Z26-086S
28	M12 LOCKNUT	1	Z23-12
29	3/4" FLAT WASHER	1	Z10-02-19
30	FILM PULL DOWN ARM ASSEMBLY	1	WD65-FPDA
31	RETAINING WASHER	1	WD60-859
32	ROLLER	1	WD60-866
33	FILM GUARD	1	WD67-FG
34	M6 GREASE NIPPLE	1	Z39-66
35	ADJUSTER HANDLE	1	Z35-55

# TANCO AUTOWAP HYDRAULIC BALE RAMP

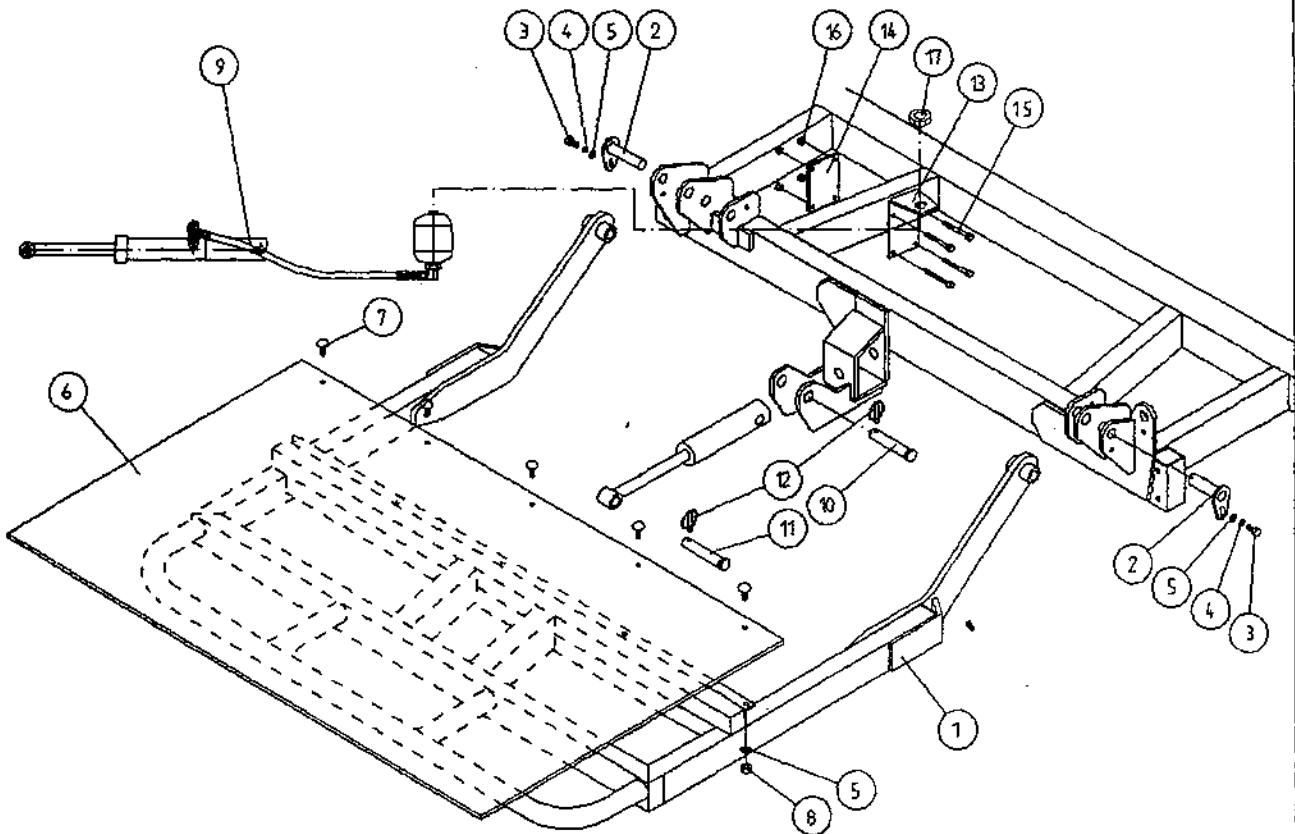

## INSTRUCTIONS FOR RECHARGING AND REDUCING PRESSURE IN HYDRAULIC BALE RAMP CYLINDER

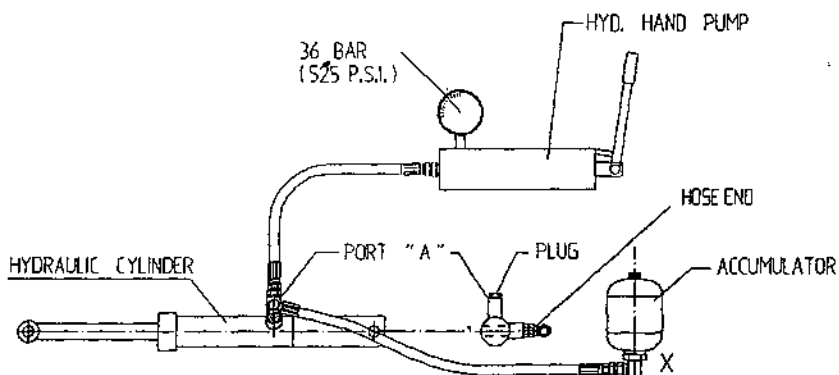

### TO RECHARGE CYLINDER:

1. REMOVE PLUG FROM PORT "A".
2. CONNECT HOSE FROM HYD. HAND PUMP TO PORT "A".
3. CHARGE CYLINDER TO A PRESSURE OF 36 BAR (525 P.S.I.)
4. BLEED AIR FROM SYSTEM BY SLACKENING HOSE CONNECTION AT BASE OF ACCUMULATOR MARKED X. RETIGHTEN CONNECTION.
5. REMOVE PUMP HOSE FROM PORT "A" AND REFIT PLUG.

### TO REDUCE PRESSURE IN CYLINDER:

1. SLACKEN CONNECTION ON HOSE END JUST ENOUGH TO ALLOW OIL TO BLEED OUT SLOWLY.
2. RETIGHTEN CONNECTION AND CHECK OPERATION OF BALE RAMP AS DETAILED IN FIG 1.
3. REPEAT PROCEDURE UNTIL OPERATION OF RAMP IS CORRECT.

FILE NAME WD66-PLZE

WD64-PL25

TANCO AUTOWRAP            MODEL  
HYDRAULIC BALE RAMP

PARTS LIST

ITEM	DESCRIPTION:	QTY:	PART NO:
1	HYDRAULIC BALE RAMP ASSY	1	WD65-HBRF
2	RAMP MAIN PIVOT PIN C/W GREASE NIPPLE	2	Z03-01-905
3	M10 HEX HD SET X 20mm LONG TUFLOCK	2	Z26-060ST
4	10mm DIA MACHINED FLAT WASHER	2	Z11-02-10
5	10mm DIA SPRING WASHER	12	Z12-02-10
6	BALE MAT	1	Z05-02-BRH
7	M10 X 30mm LONG CUP HD.SQ BOLTS	5	Z13-112
8	M10 HEX NUTS	5	Z18-10
9	HYDRAULIC RAM C/W ACCUMULATOR	1	Z01-01-AWD
10	SPAREX PIN	1	Z03-04-74
11	SPAREX PIN	1	Z03-04-73
12	7/16" DIA LINCH PIN	2	Z03-22-06
13	ACCUMULATOR MOUNTING PLATE	1	WD65-AMP
14	CLAMPING PLATE	1	WD65-231
15	M8 HEX HD BOLT X 80mm LONG	4	Z26-050B
16	M8 LOCKNUT	4	Z23-08
17	M28 X 1.5 PITCH HEX NUT	1	Z18-28

**TANCO AUTOWRAP TRAILED MODELS  
LIGHTING KIT**

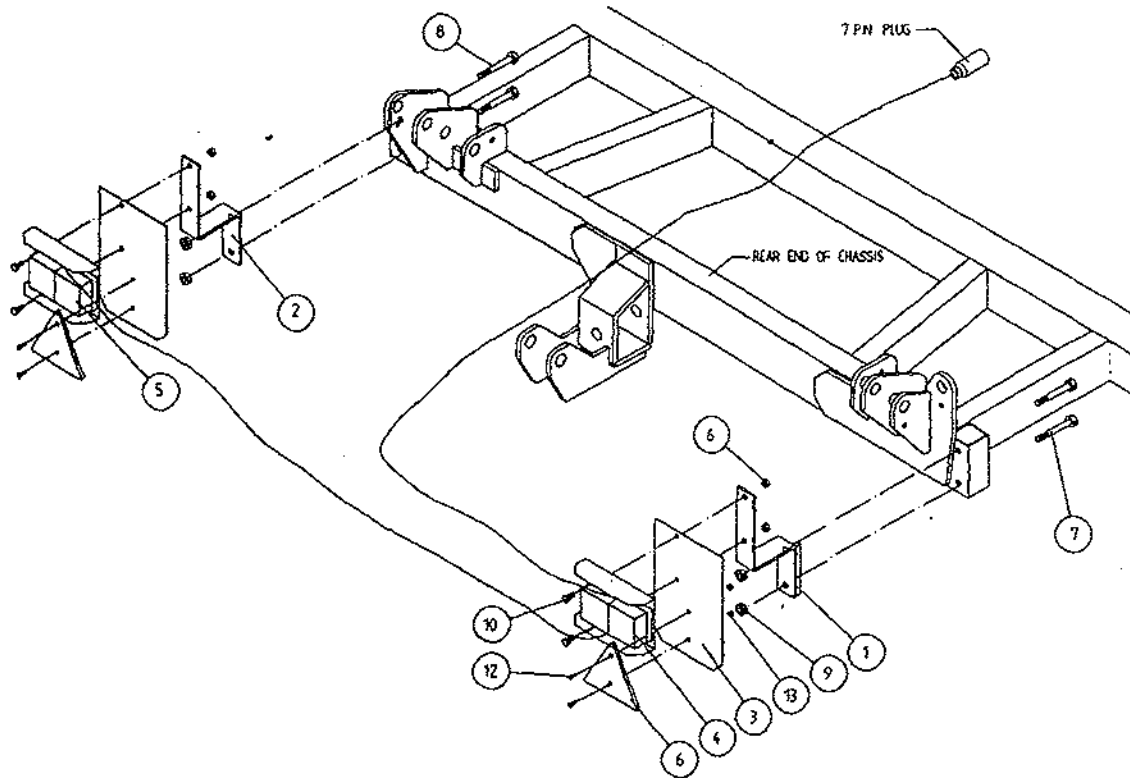

ITEM NO	DESCRIPTION	QTY	PART-NO.
1.	LIGHT MOUNTING BRACKET RHS	1	WD60-LMB
2.	LIGHT MOUNTING BRACKET LHS	1	WD60-899
3.	LIGHT MOUNTING PLATE	2	WD60-898
4.	LIGHT CLUSTER RHS	1	Z05-30R
5.	LIGHT CLUSTER LHS	1	Z05-30L
6.	TRIANGULAR REFLECTOR	2	Z04-62
7.	M12 HEX HD BOLT X 100 LONG	2	Z26-092B
8.	M12 HEX HD BOLT X 90 LONG	2	Z06-091B
9.	M12 LOCKNUT	4	Z23-12
10.	M8 HEX HD SET X 20 LONG	4	Z26-39S
11.	M8 LOCKNUT	4	Z23-08
12.	M6 CHEESE HEAD SET X 20 LONG	4	Z13-15
13.	M6 LOCKNUT	4	Z23-06



## EC DECLARATION OF CONFORMITY

according to Directives 89/392/336/EEC  
as amended

Manufacturer

TANCO ENGINEERING CO. LTD.  
BAGENALSTOWN  
CO. CARLOW  
IRELAND

Certifies that the following product:

AUTOWRAP

MODEL

450S/550S/550A

SERIAL No.

D2000 - D3000

To which this declaration relates, corresponds to the essential requirements of  
the Directive 89/392/336/EEC as amended.

To conform to these essential health and safety requirements, the provisions of the  
following harmonized standards were particularly considered:

*EN 292 - 1,2 , EN 294 , EN 1152 , prEN 703 , prEN 811 ; prEN 1553 , prEN 982.*

DATE 01-01-96

SIGNATURE

*Alfred A Cox*

ALFRED A. COX, TECHNICAL DIRECTOR